



KENDRION INDUSTRIAL BRAKES

High Torque Line

High Torque

Operating Instructions 86 611..P00

Types: 86 61103K00 86 61104K00 86 61105K00 86 61106K00
86 61107K00 86 61108K00 86 61109K00 86 61110K00
86 61111K00 86 61114K00 86 61116K00 86 61121K00
86 61104P00 86 61105P00 86 61106P00 86 61107P00
86 61108P00 86 61109P00 86 61110P00 86 61111P00
86 61114P00 86 61116P00 86 61121P00

Contents

1. General	3
1.1 Introduction	3
1.2 Manufacturer	3
1.3 Product, types, versions and product numbers	3
1.4 Standards and directives	4
1.5 Conventions used in these operating instructions	4
1.6 Manufacturer's liability	5
1.7 Relevant documents	5
1.8 Declaration of Incorporation (in accordance with Annex II, part 1, Section B of Machinery Directive 2006/42/EC)	6
1.9 Declarations of Conformity	7
1.9.1 EU Declaration of Conformity	7
1.9.2 UK Declaration of Conformity	8
2. Safety	9
2.1 Symbols, signs and signal words in safety messages	9
2.2 Intended use	11
2.3 General safety information	11
2.3.1 Set-up	11
2.3.2 Putting into service	12
2.3.3 Assembly	12
2.3.4 Operation and use	12
2.3.5 Maintenance, repair and replacement	13
3. Product description	14
3.1 Operating principle	14
3.2 Design of brake types 86 611..K00 (with armature type 300 for manual adjustment of the rated air gap s_N)	14
3.3 Design of brake types 86 611..P00 (with armature type 800 for automatic adjustment of the rated air gap s_N)	16
4. Installation	18
4.1 Mechanical installation	18
4.1.1 Mechanical installation of brake types 86 611..K00 with armature type 300	22
4.1.2 Mechanical installation of brake types 86 611..P00 with armature type 800	23
4.2 Electrical connection and operation	25
4.2.1 Electrical connection of the High Torque brake	25
4.2.2 DC power supply	26
4.2.3 AC power supply	28
4.3 Electromagnetic compatibility	31
4.4 Putting into service	33
5. Maintenance, repair and replacement	36
5.1 Maintenance and checks	36
5.2 Brake repair and replacement in case of failure	39
5.3 Spare parts and accessories	40
6. Condition at delivery, transport and storage	41
7. Emissions	41
7.1 Noise	41
7.2 Heat	41
8. Troubleshooting	42
9. Tools and measuring instruments for installation, maintenance and troubleshooting	43
10. Definitions	44
11. Technical specifications	46
12. Product number / type number / version number	49
13. Specialist repair shops	49
14. Revision history	49

Document information:

Issued by: Kendrion (Villingen) GmbH

Replaces document: -

Document type: translation of original German operating instructions BA 86 611..P00

Document title: BA 86 611..P00 Englisch

Last updated: 02/03/2022

Replaces the issue dated: 13/03/2020

Document status: released

1. General

1.1 Introduction

These operating instructions describe the operating principle and features of the High Torque brake types 86 611..P00 and 86 611..K00. The High Torque brakes are intended to be directly incorporated into electric motors, hereinafter referred to as **machines**, and are used to stop and firmly lock or secure the machine shaft (e.g. motor shaft).

The safety information provided in this manual must be strictly observed during the set-up of the machine and during the start-up, operation and maintenance of the High Torque brakes.

Should any queries arise with respect to torques, torque variations, installation position, wear, wear reserve, switching work, break-in conditions, release range, ambient conditions and the like, please contact Kendrion (Villingen) and ask for clarification before starting to use the brake. High Torque brakes are not ready-to-use devices, but are intended to be incorporated into or assembled with other equipment. Consequently, they will be referred to as **components** in the following sections.

1.2 Manufacturer

Kendrion (Villingen) GmbH
 Wilhelm-Binder-Str. 4-6
 78048 Villingen-Schwenningen
 Germany

Tel: +49 7721 877-1417
 Email: sales-ids@kendrion.com

1.3 Product, types, versions and product numbers

Product: High Torque, electromagnetically released permanent-magnet single-face brake

Types:	86 61103K00	86 61104K00	86 61105K00	86 61106K00	86 61107K00
	86 61108K00	86 61109K00	86 61110K00	86 61111K00	86 61114K00
	86 61116K00	86 61121K00	86 61104P00	86 61105K00	86 61106P00
	86 61107P00	86 61108P00	86 61109P00	86 61110P00	86 61111P00
	86 61114P00	86 61116P00	86 61121P00		

Types	Version number	Product number ¹⁾	Versions
86 61103K00	XXXX	86 61103K00-XXXX	Flange hub (5) bore, rated voltage U _N
86 61104K00	XXXX	86 61104K00-XXXX	
86 61105K00	XXXX	86 61105K00-XXXX	
86 61106K00	XXXX	86 61106K00-XXXX	
86 61107K00	XXXX	86 61107K00-XXXX	
86 61108K00	XXXX	86 61108K00-XXXX	
86 61109K00	XXXX	86 61109K00-XXXX	
86 61110K00	XXXX	86 61110K00-XXXX	
86 61111K00	XXXX	86 61111K00-XXXX	
86 61114K00	XXXX	86 61114K00-XXXX	
86 61116K00	XXXX	86 61116K00-XXXX	
86 61121K00	XXXX	86 61121K00-XXXX	

Table 3/1: List of brake types and versions of the High Torque brake types 86 611..K00 (with armature 300 for manual adjustment of the rated air gap s_N)

1) Please refer to Section 12 for more details on the product number.

Types	Version number	Product number ²⁾	Versions
86 61104P00	XXXX	86 61104P00-XXXX	Flange hub (5) bore, rated voltage U _N
86 61105P00	XXXX	86 61105P00-XXXX	
86 61106P00	XXXX	86 61106P00-XXXX	
86 61107P00	XXXX	86 61107P00-XXXX	
86 61108P00	XXXX	86 61108P00-XXXX	
86 61109P00	XXXX	86 61109P00-XXXX	
86 61110P00	XXXX	86 61110P00-XXXX	
86 61111P00	XXXX	86 61111P00-XXXX	
86 61114P00	XXXX	86 61114P00-XXXX	
86 61116P00	XXXX	86 61116P00-XXXX	
86 61121P00	XXXX	86 61121P00-XXXX	

Table 4/1: List of brake types and versions of the High Torque brake types 86 611..P00 (with armature 800 for automatic adjustment of the rated air gap s_N)

1.4 Standards and directives

The state-of-the-art brakes have been designed, built and tested in accordance with the requirements of DIN VDE 0580 concerning electromagnetic devices and components. Being classified as “electromagnetic components”, High Torque brakes are also subject to the Low Voltage Directive 2014/35/EU. The user is required to employ suitable switching devices and controls to ensure use of the brakes in accordance with EMC Directive 2014/30/EU.

1.5 Conventions used in these operating instructions

The conventions used in these operating instructions for the representation of information make the manual easier to read and understand. The conventions are listed in Table 4/1.

Conventions / Examples	Type of information	Meaning
Table 4/1	Table	Reference to information provided in a table
Fig. 4/1	Figure	Reference to information provided in a figure
•	Numbered items	Tasks or steps to be performed and/or additional information
Section 2.1	Section	Reference to one or more sections
¹⁾	Footnote	Additional information
(1.2)	Reference numeral	Reference to an item in a figure or table, accompanied by additional information relating to the designation or identification of a component part
(e.g. motor shaft)	Addition	Supplementary information
..	Wildcard	Wildcard for different brake sizes
XXXX	Wildcard	Wildcard for different versions
Components	Highlighting (bold text)	Highly relevant information

Table 4/1: Conventions used for the representation of information

Special conventions used for the representation of safety messages and safety-related information are explained in Section 2.1.

²⁾ Please refer to Section 12 for more details on the product number.

1.6 Manufacturer's liability

The manufacturer will not assume any responsibility for damage caused by failure to use the components in accordance with their intended use or by failure to observe safety information and other instructions provided in this document. The information in this manual was correct and up-to-date before going to print. The information contained herein shall not entitle users to raise claims with respect to components purchased at an earlier date.

1.7 Relevant documents

- High Torque Line brochure for types 86 611..K00 and 86 611..P00
- Technical Customer Information TKU 86 611..P01
- Offer drawings 86 611..K00-O and 86 611..P00-O

1.8 Declaration of Incorporation (in accordance with Annex II, part 1, Section B of Machinery Directive 2006/42/EC)

We hereby declare that the products below comply with the essential health and safety requirements specified in Annex I of Machinery Directive 2006/42/EC:

Annex I, General Principles and sections 1.1.2, 1.1.3, 1.1.5, 1.3.2, 1.5.1

The partly completed machinery must not be put into service until the final machinery into which it is to be incorporated has been declared in conformity with the provisions of Machinery Directive 2006/42/EC. The relevant technical documentation required for the partly completed machinery has been compiled in accordance with Annex VII, part B of Machinery Directive 2006/42/EC. The manufacturer undertakes to submit an electronic copy of the relevant technical documentation compiled for the partly completed machinery if reasonably requested by national authorities.

Manufacturer: Kendrion (Villingen) GmbH
Wilhelm-Binder-Str. 4-6
78048 Villingen-Schwenningen
Germany

Person authorized to compile the documentation: Dominik Hettich
Kendrion (Villingen) GmbH
Wilhelm-Binder-Str. 4-6
78048 Villingen-Schwenningen
Germany

Applied harmonized standards and other technical standards and regulations:

- EN 60529 Enclosure protection ratings
- DIN VDE 0580 Electromagnetic devices and components
- EN ISO 12100 Safety of machinery - General principles for design - Risk evaluation and risk reduction

Product: High Torque, electromagnetically released permanent-magnet single-face brake

Types:	86 61103K00	86 61104K00	86 61105K00	86 61106K00	86 61107K00
	86 61108K00	86 61109K00	86 61110K00	86 61111K00	86 61114K00
	86 61116K00	86 61121K00	86 61104P00	86 61105K00	86 61106P00
	86 61107P00	86 61108P00	86 61109P00	86 61110P00	86 61111P00
	86 61114P00	86 61116P00	86 61121P00		

Kendrion (Villingen) GmbH

Villingen
02/03/2022

Authorized signatory:

Dominik Hettich
(Head of Development)

1.9 Declarations of Conformity

1.9.1 EU Declaration of Conformity

We hereby declare that the products below, specifically the product versions placed on the market, have been designed and built, in accordance with the requirements of the following EU directives.

EU directives:

- 2014/35/EU Harmonization of the laws of the member States relating to the making available on the market of electrical equipment designed for use within certain voltage limits (Low Voltage Directive)
- 2011/65/EU Restriction of the use of certain hazardous substances in electrical and electronic equipment (RoHS Directive)

The products are classified as category 11 equipment subject to Directive 2011/65/EU (RoHS Directive). This declaration will cease to be valid if modifications are made to the product without prior permission from the manufacturer.

Manufacturer: Kendrion (Villingen) GmbH
Wilhelm-Binder-Str. 4-6
78048 Villingen-Schwenningen
Germany

Authorized representative: Dominik Hettich
Kendrion (Villingen) GmbH
Wilhelm-Binder-Str. 4-6
78048 Villingen-Schwenningen
Germany

Applied harmonized standards and other technical standards and regulations:

- EN 60529 Enclosure protection ratings
- DIN VDE 0580 Electromagnetic devices and components
- EN ISO 12100 Safety of machinery - General principles for design - Risk evaluation and risk reduction

Product: High Torque, electromagnetically released permanent-magnet single-face brake

Types:	86 61103K00	86 61104K00	86 61105K00	86 61106K00	86 61107K00
	86 61108K00	86 61109K00	86 61110K00	86 61111K00	86 61114K00
	86 61116K00	86 61121K00	86 61104P00	86 61105K00	86 61106P00
	86 61107P00	86 61108P00	86 61109P00	86 61110P00	86 61111P00
	86 61114P00	86 61116P00	86 61121P00		

Kendrion (Villingen) GmbH

Villingen
02/03/2022

Authorized signatory:
Dominik Hettich
(Head of Development)

1.9.2 UK Declaration of Conformity

We hereby declare that the products below, specifically the product versions placed on the market, have been designed and built, in accordance with the requirements of the following UK statutory instruments.

UK statutory instruments:

- SI 2016 No. 1101 Consumer Protection, Health and Safety; The Electrical Equipment (Safety) Regulations 2016
- SI 2012 No. 3032 Environmental Protection; The Restriction of the Use of Certain Hazardous Substances in Electrical and Electronic Equipment Regulations 2012

This declaration will cease to be valid if modifications are made to the product without prior permission from the manufacturer.

Manufacturer: Kendrion (Villingen) GmbH
 Wilhelm-Binder-Str. 4-6
 78048 Villingen-Schwenningen
 Germany

Authorized representative: Dominik Hettich
 Kendrion (Villingen) GmbH
 Wilhelm-Binder-Str. 4-6
 78048 Villingen-Schwenningen
 Germany

Applied harmonized standards and other technical standards and regulations:

- EN 60529 Enclosure protection ratings
- DIN VDE 0580 Electromagnetic devices and components
- EN ISO 12100 Safety of machinery - General principles for design - Risk evaluation and risk reduction

Products: High Torque, electromagnetically released permanent-magnet single-face brake

Types:	86 61103K00	86 61104K00	86 61105K00	86 61106K00	86 61107K00
	86 61108K00	86 61109K00	86 61110K00	86 61111K00	86 61114K00
	86 61116K00	86 61121K00	86 61104P00	86 61105K00	86 61106P00
	86 61107P00	86 61108P00	86 61109P00	86 61110P00	86 61111P00
	86 61114P00	86 61116P00	86 61121P00		

Kendrion (Villingen) GmbH

Villingen
 02/03/2022

Authorized signatory:

Dominik Hettich
 (Head of Development)

2. Safety

The components described in these operating instructions have been designed and built on the basis of an analysis of hazards and in accordance with the requirements of the applicable harmonized standards and technical specifications. They correspond to the state of the art and provide maximum safety. However, safety hazards can only be avoided if the machine owner takes adequate precautions and makes sure that safety instructions are strictly adhered to. It is the duty of the machine owner to plan these measures and to monitor their implementation.

The machine owner is required to ensure that:

- the components are only used in accordance with their intended use (see Section 2.2 – Intended use, and Section 3 – Product description).
- the components are in perfect working order and checked at regular intervals.
- a complete and fully legible copy of these operating instructions is kept available at the place of installation and use of the components at all times.
- putting into service, maintenance and repair are only performed by authorized and suitably qualified personnel.
- such personnel are kept informed on all relevant occupational safety and environmental protection issues and familiar with the operating instructions and with the safety information contained herein.
- the components are not exposed to other strong magnetic fields.

IMPORTANT
READ THESE OPERATING INSTRUCTIONS CAREFULLY
BEFORE STARTING TO USE THE PRODUCTS!
KEEP THESE OPERATING INSTRUCTIONS IN A SAFE PLACE FOR FUTURE REFERENCE!

2.1 Symbols, signs and signal words in safety messages

Safety messages that warn users of potential risks of personal injury or property damage or indicate other important information are highlighted by the safety alert symbols, information signs and signal words shown in Table 9/1.



Personal injury			
Symbol	Signal word	Indicates...	Potential consequences
	DANGER	an imminent hazardous situation which, if not avoided, will result in death or serious injury	Death or serious injury
	WARNING	a potentially hazardous situation which, if not avoided, could result in death or serious injury	Death or serious injury
	CAUTION	a potentially hazardous situation which, if not avoided, could result in minor or moderate injury	Minor or moderate injury
Property damage			
Symbol	Signal word	Indicates...	Potential consequences
	NOTICE	potential property damage or environmental damage	Damage to the component or to the environment
Information			
Symbol	Signal word	Provides...	
	IMPORTANT	information on the safe use and operation of the component	

Table 9/1: Safety alert symbols, information signs and signal words used in safety messages

Structure and colour of hazard alerting, non-hazard alerting and instructional safety messages

Hazard alerting safety messages (potential personal injury):

Signal word: DANGER



Hazard type and source

- Potential consequences if not avoided
- Hazard prevention measures

Signal word: WARNING



Hazard type and source

- Potential consequences if not avoided
- Hazard prevention measures

Signal word: CAUTION



Hazard type and source

- Potential consequences if not avoided
- Hazard prevention measures

Non-hazard alerting safety messages (potential property damage):

Signal word: NOTICE



Type and source of potential property damage

- Potential consequences if not avoided
- Property damage prevention measures

Instructional safety messages:

Signal word: IMPORTANT



Information for the safe use and operation of the component

Other warning signs used:





Symbol	Warning	Symbol	Warning
	Magnetic field hazard		Hot surface hazard
	Electricity hazard		Hand injury hazard

Table 10/1: Specific warning signs used in this manual

The safety information provided in these operating instructions with regard to potential personal injury and its consequences (death, serious injury, minor or moderate injury) applies **exclusively** if the brakes are incorporated into and operated in electrical machinery (see Section 2.2 – Intended use).

2.2 Intended use

The components described in these operating instructions are intended to be incorporated into electrical machinery, in particular electric motors, for use in industrial installations.

IMPORTANT



The components must be used in accordance with the operating requirements detailed in these operating instructions. The specified rated power limits must not be exceeded. Operation in potentially explosive or firedamp atmospheres is strictly forbidden.

2.3 General safety information

Built-in brakes feature hazardous live components and rotating parts and may exhibit hot surfaces. Any work associated with the transport, connection, putting into service and periodical maintenance of the brakes must be carried out by authorized and suitably qualified specialist personnel in accordance with EN 50110-1, EN 50110-2 and IEC 60364-1. Failure to observe safety, operating and maintenance instructions may cause serious personal injury and property damage. Whenever special measures are required in accordance with the instructions contained herein, such measures should be agreed with the brake manufacturer before setting up the machinery into which the brake is to be incorporated. Should any queries arise with respect to torques, torque variations, installation positions, wear, wear reserve, switching work, break-in conditions, release range, ambient conditions and the like, please contact the manufacturer and ask for clarification before using the brake. Retrofitting or modification of the brake is subject to the approval from Kendrion (Villingen). Accident prevention regulations applying to the specific field of application must be strictly observed.

IMPORTANT



The components described in this manual are **not designed for use as “safety brakes”**. This means that negative effects on the brake torque (e.g. brake torque variations, reduced torque stability) arising from adverse ambient conditions that are beyond the user's control (e.g. higher ambient temperatures or humidity, contaminated ambient air etc.) cannot be ruled out. If such phenomena occur, the system user is required to ensure that the component is subjected to a break-in process at regular intervals to achieve the full braking effect. The break-in process parameters specified in Table 47/1 or Table 47/2 apply.

2.3.1 Set-up

Requirements in terms of the permissible number of switching operations per hour and the maximum switching work per switching operation specified in the technical specifications (see Table 46/1) must be strictly observed during the set-up of machinery and installations (jog mode). Failure to observe these instructions may irreversibly diminish the braking effect and cause malfunctions. The rated operating conditions are those specified in DIN VDE 0580. The protection rating conforms to EN 60529. In case of deviations, special measures must be taken after prior consultation with the brake manufacturer.

IMPORTANT



Depending on the humidity and the degree of condensation, ensure that the brake armature (4) cannot freeze to the surfaces of the flange (3) or housing (2) involved in the friction process, e.g. due to ice formation and crystallization if ambient temperatures fall below -5°C or if the machinery (e.g. motor) remains unpowered for prolonged periods of time.

The gradual brake wear (only with dynamic brakes or holding brakes with emergency stop function; see Table 46/1 – Technical specifications) must be taken into consideration in the set-up of the machinery (e.g. motor).

2.3.2 Putting into service

Do not put the components into service if:

- power supply cables/wires or connections (e.g. wire leads (1.3)) are damaged,
- the sheath of the field coil (1.2) is damaged.
- other defects are suspected.



DANGER



Electricity hazards from incorrect electrical connection of the component!

- Fatal electric shock hazard.
- All work must be performed by qualified specialist personnel only. Check that no voltage is present before connecting the component to the power supply. The specifications on the rating plate and the information provided in the circuit diagram, which (if available) may be located in the terminal box of the machine (e.g. motor) or in the operating instructions, must be strictly observed.

2.3.3 Assembly

The voltage level and voltage type specified on the rating plate (9) must be strictly observed when connecting the components described in these operating instructions. Sufficient heat dissipation must be ensured when the component is mounted to or incorporated into machinery. Adequate precautions must be taken to avoid overvoltage during disconnection or voltage peaks. The magnetic field of the brake may cause interference outside the brake or even feedback to the brake in case of adverse installation conditions. Should you have queries concerning mounting and fitting conditions, please contact the brake manufacturer and ask for clarification.

Adequate safety measures (to DIN 31000 / DIN VDE 0100-420) must be taken by the brake user to avoid hazards to persons or property damage caused by:

- direct or indirect effects of electromagnetic fields,
- heated components,
- moving parts.

2.3.4 Operation and use

Ensure that live components such as plug contacts, the field coil and similar parts are not exposed to water. The brake cable connections must not be crushed, squeezed or exposed to mechanical loads. Make absolutely sure that the friction surfaces of the friction components are not contaminated with grease, oil or other fluids to avoid substantial torque reduction. Bear in mind that the original torque cannot be restored even if the friction surfaces are cleaned after contact with fluids. Due to the diverse ambient conditions in which the brakes may be used, always check that the brake is in perfect working order before putting it into service.

The components are factory-treated with a corrosion inhibitor to provide basic corrosion protection during storage and operation in dry environments (no condensation).

IMPORTANT



The balance quality of the component's armature system (AS) has not been classified to DIN ISO 21940-11. Consequently, the required balance quality must be agreed between the manufacturer and customer in each individual case.

IMPORTANT

The maximum operating air gap s_{Bmax} (see Table 46/1 – Technical specifications) must not be exceeded throughout the entire brake service life. Please refer to Section 5 (Maintenance, repair and replacement) for details. The M_4 transmissible torque (see Table 46/1 – Technical specifications) is not fully reached until the break-in process has been completed (burnishing of friction surfaces). The relevant break-in parameters are specified in Table 47/1 or Table 47/2. The brake torque may drop during the operating phase if the brake is operated as a mere holding brake with little or no friction work or if adverse factors occur in the brake environment (see Section 2.3). In this case, the brake user should ensure that a break-in process as specified in Table 47/1 or Table 47/2 is conducted at regular intervals.

NOTICE**Risk of damage to the field coil (1.2) in case of brake operation beyond the permissible limits!**

- Release of the High Torque brake may no longer be possible.
- Potential malfunction of the machine (e.g. motor).
- During brake operation, ensure that the coil temperature does not rise above the permissible limit temperature applicable to the insulating materials of the specified insulation class (see Table 46/1 – Technical specifications). Fast cooling of the field coil with scavenging air is not allowed. Ensure that the relative humidity and ambient temperature remain within the permissible range (see rated operating conditions in Table 46/2).
- A maximum 6g continual shock load over a lifecycle of 2000 operating hours as well as vibration loads with a maximum excursion of 1.5 mm and a maximum 6g acceleration within a frequency band of 10 to 2000 Hz are permissible for the High Torque brakes. In addition, the mechanical conditions (M) according to EN IEC 60721-3-3 (see rated operating conditions in Table 46/2) must be observed.

**DANGER****Electromagnetic field hazards during brake operation!**

- Indirect effects of electromagnetic fields may cause disturbances and failures of cardiac pacemakers and other implants.
- Serious or even fatal injury hazard.
- Keep at a safe distance from the component during operation.

2.3.5 Maintenance, repair and replacement

Service, maintenance, repair or replacement of the components must only be carried out by qualified specialist personnel in accordance with EN 50110-1, EN 50110-2 and IEC 60364-1. Failure to perform repairs in accordance with the specifications may cause serious personal injury or property damage. Make sure that the components are unpowered when carrying out maintenance work.

3. Product description

3.1 Operating principle

The High Torque brake is designed to operate dry. The force generated by a permanent magnetic field is utilized to produce the braking effect.

The permanent magnetic field attracts the armature (4) and pulls it in frictional contact with the housing (2) and flange (3). The resulting friction force generates the brake torque.

To neutralize the braking action, the magnetic flux of the permanent magnets acting on the armature (4) is offset by an alternate electromagnetic field generated when DC voltage is applied to the field coil (1.2) of the High Torque brake. As a result, the brake is released (electromagnetically released system).

Except for the force exerted by the segment springs (7), the machine shaft (12) to be blocked or secured is not exposed to any other axial force.

3.2 Design of brake types 86 611..K00 (with armature type 300 for manual adjustment of the rated air gap s_N)

The firmly fitted field coil (1.2) is installed between the housing (2) and flange (3) of the High Torque brake. The wire leads (1.3) required to connect the field coil (1.2) exit at defined radial positions on the brake circumference. The permanent magnets (1.1) installed radially between the housing (2) and flange (3) generate the magnetic field required to produce the braking action. The armature (4) is connected with the flange hub (5) by means of the segment springs (7) and rivet fasteners (6) to achieve a centred, frictionless, torsion-proof and axially movable connection. This ensures zero-backlash transmission of the brake torque to the machine shaft (12) when the brake is engaged and reliable operation with zero residual torque when the brake is released, regardless of whether the brake is installed in horizontal or vertical position. Owing to this design, the brakes are ideal for servo motor applications. The flange hub (5) is firmly connected to the machine shaft (e.g. motor shaft) (12) by the set screws (8) to create a frictional connection.

IMPORTANT



The rated air gap s_N (see Table 46/1 – Technical specifications) between the armature (4) and housing (2) of the High Torque brake types 86 611..K00 must be adjusted manually during brake assembly.

List of reference numerals in Fig. 15/1:

1.1	Permanent magnet	9	Rating plate
1.2	Field coil	10	Mounting screw
1.3	Wire leads	11	Mounting surface of machine end shield (14)
2	Housing	12	Machine shaft (e.g. motor shaft)
3	Flange	13	Bearing (e.g. deep groove ball bearing of motor)
4	Armature	14	Machine end shield (e.g. motor end shield)
5	Flange hub	15	Machine housing (e.g. motor housing)
6	Rivet fastener	Z	Centring point
7	Segment spring	B	Opening for checking / measuring the air gap 's'
8	Set screw (x3)		

Table 14/1: List of reference numerals of High Torque brake types 86 611..K00 with armature type 300

High Torque brake types 86 611..K00

a)

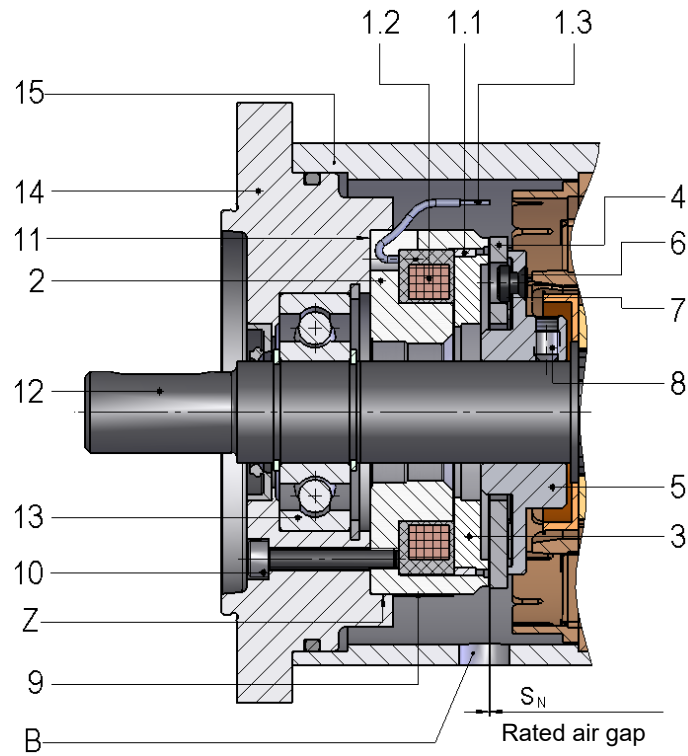

b)

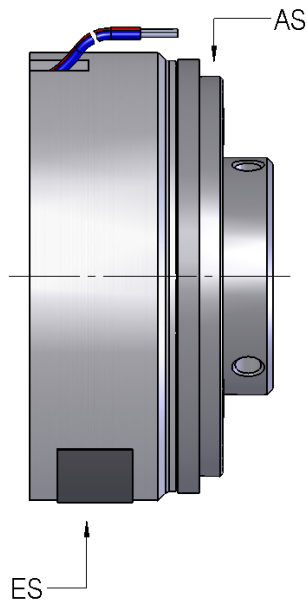

Fig. 15/1: High Torque brake types 86 611..K00 with armature type 300
 a) Attached to mounting surface (11) of the machine (e.g. motor) (example)
 b) Armature system (AS) and excitation system (ES)

3.3 Design of brake types 86 611..P00 (with armature type 800 for automatic adjustment of the rated air gap s_N)

High Torque brake types 86 611..P00 with armature type 800 differ from brake types 86 611..K00 (see Section 3.2) in the following details:

The geometry of the flange hub (5) is designed in such a way that precise axial positioning of the armature system (AS) relative to the excitation system (ES) is possible between the contact shoulder of the machine shaft (e.g. motor shaft) (12) and the inner ring of the ball bearing (13). The flange hub (5) is firmly connected to the machine shaft (e.g. motor shaft) (12) by the set screws (8) to create a frictional connection. If necessary, a feather key can be used (only for flange hub versions with keyway) to achieve an additional positive-locking connection between the flange hub (5) and machine shaft (e.g. motor shaft) (12).

IMPORTANT

i The rated air gap s_N (see Table 46/1 – Technical specifications) between the armature (4) and housing (2) of the High Torque brake is automatically achieved during final assembly of the machine (e.g. motor). The distance 'L' (see Fig. 17/1) between the outer ring of the ball bearing (13) (limit stop for ball bearing (13) in machine end shield (e.g. motor end shield) (14)) and the stop shoulder of the machine shaft (e.g. motor shaft) (12) (limit stop for flange hub (5)) must be dimensioned in such a way that the required rated air gap s_N (see Table 46/1 – Technical specifications) is automatically adjusted when the brake is assembled and incorporated into the machine (e.g. motor).

IMPORTANT

i The distance 'L' (see Fig. 17/1) results from the length L_1 of the flange hub (5) (see Table 20/1 or offer drawings for the components) plus the width 'b' of the ball bearing used (13) (distance $L = \text{length } L_1 + \text{width } b$). The ball bearings (13) recommended for incorporating the component into the machine (e.g. motor) are specified in the offer drawings of the relevant components.

List of reference numerals in Fig. 17/1:

1.1	Permanent magnet	9	Rating plate
1.2	Field coil	10	Mounting screw
1.3	Wire leads	11	Mounting surface of machine end shield (14)
2	Housing	12	Machine shaft (e.g. motor shaft)
3	Flange	13	Bearing (e.g. deep groove ball bearing of motor)
4	Armature	14	Machine end shield (e.g. motor end shield)
5	Flange hub	15	Machine housing (e.g. motor housing)
6	Rivet fastener	Z	Centring point
7	Segment spring	B	Opening for checking / measuring the air gap 's'
8	Set screw (x3)		

Table 16/1: List of reference numerals of High Torque brake types 86 611..P00 with armature type 800

High Torque brake types 86 611..P00

a)

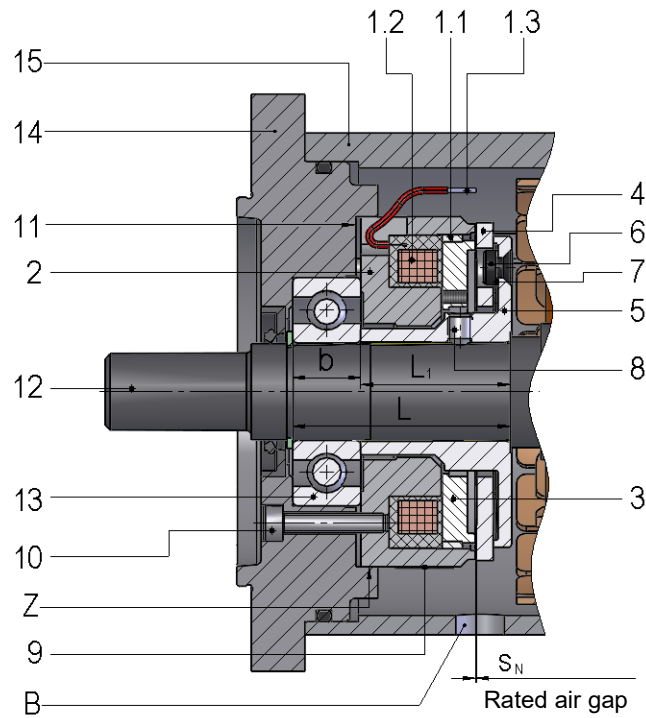

b)

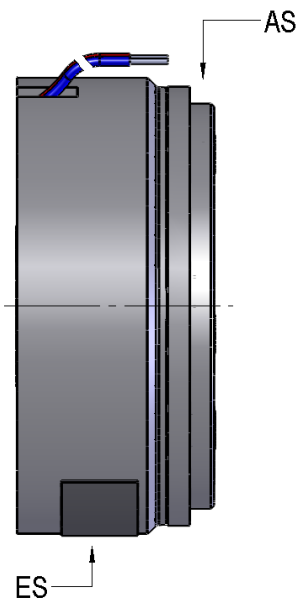

Fig. 17/1: High Torque brake types 86 611..P00 with armature type 800
 a) Attached to mounting surface (11) of the machine (e.g. motor) (example)
 b) Armature system (AS) and excitation system (ES)

4. Installation

4.1 Mechanical installation

The mechanical installation procedure and installation sequence differ between the different High Torque brake types 86 611..K00 and 86 611..P00 (see Sections 4.1.1 and 4.1.2).

IMPORTANT



The component should be incorporated into the machine (e.g. motor) on the side of the preloaded ball bearing (13) (e.g. fixed bearing (A-side) of the motor). Magnetic interference fields may adversely affect reliable brake operation. Consequently, the brake should always be installed outside the reach of magnetic interference fields.

To ensure perfect operation of the High Torque brake, check that the mounting surface (11) of the machine end shield (e.g. motor end shield) (14) and the machine shaft (e.g. motor shaft) (12) meet the following requirements before installing the brake:

Requirements of mounting surface (11) of machine end shield (e.g. motor end shield) (14):

- Axial runout (simple runout) relative to machine shaft (e.g. motor shaft) (12) max. 0.05 mm (measuring radius = pitch circle diameter of brake, measurement to EN 50347)
- Positional deviation of mounting bores for mounting screws (10) on pitch circle max. \varnothing 0.2 mm, reference element: axis of machine shaft (12)
- Concentricity of shoulder for centring the housing (2) max. \varnothing 0.2 mm, reference element: axis of machine shaft (e.g. motor shaft) (12)
- Material: steel, cast iron, aluminium – with excellent thermal conductivity
- Absence of oil and grease
- Surface hardness min. 100 HB; surface roughness $R_{zmax}16$

IMPORTANT



Correct centring of the brake is accomplished by centring the outside diameter of the housing (2) (see offer drawing of relevant component). This is essential to ensure correct brake operation. The axial runout of the pole faces of the brake relative to the machine shaft (e.g. motor shaft) (12) must not exceed 0.05 mm after the screws have been tightened. The maximum permissible positional deviation of the mounting screws in the machine end shield (e.g. motor end shield) (14) must not exceed the specifications to enable correct assembly of the brake to the mounting surface (11) of the machine end shield (e.g. motor end shield) (14).

NOTICE



Risk of brake damage caused by incorrect design of the mounting surface (11) of the machine end shield (e.g. motor end shield) (14)!

- Putting into service of the High Torque brake and machine (e.g. motor) may not be possible.
- Potential malfunction of the High Torque brake and machine (e.g. motor).
- Potential reduction of the service life of the High Torque brake.
- The mounting surface (11) of the machine end shield (e.g. motor end shield) (14) must be dimensioned in such a way that the screw connection is not affected by setting effects or similar phenomena. The specifications in the paragraph 'Requirements of mounting surface (11) of machine end shield (e.g. motor end shield) (14)' must be observed.

Requirements of machine shaft (e.g. motor shaft) (12):

- No impact marks or other damage to machine shaft (e.g. motor shaft) (12)
- Radial runout (simple runout) of machine shaft (e.g. motor shaft) (12) max. 0.05 mm (test according to EN 50347)
- Surface roughness R_{zmax} 4 in the area of the flange hub (5)

IMPORTANT



The machine shaft (e.g. motor shaft) (12) should be made of suitable materials with sufficient strength, ductility and grade such as E335, S355, or 42CrMoS4 steels etc. In the area of the flange hub (5) the machine shaft (12) should be designed with tolerance class g6 (types 86 611..K00) or s6 (types 86 611..P00, for low interference fit).



WARNING



Hazards from brake failure caused by incorrect design of the machine shaft (e.g. motor shaft) (12)!

- Uncontrolled movements of the machine shaft (e.g. motor shaft) (12) may cause injury hazards if persons are present within the confines and/or working range of the installation.
- Uncontrolled **extremely fast** movements of the machine shaft (e.g. motor shaft) (12) may cause death if persons are present within the confines and/or working range of the installation.
- The brake user is required to ensure that the tolerance, strength and quality of the machine shaft (e.g. motor shaft) (12) are suitable to achieve reliable and safe transmission of the generated brake torque from the flange hub (5) to the machine shaft (e.g. motor shaft) (12) over the entire brake service life.

Installation of the excitation system (ES) and armature system (AS):

Suitable mounting screws (10) are required (e.g. socket head cap screws to ISO 4762; property class 8.8) for the installation of the excitation system (ES) (see Table 20/1, not supplied). The armature system (AS) is fixed with a total of three set screws (8) (e.g. to ISO 4029, property class 45H) (see Table 20/1, not supplied).

IMPORTANT



Tighten the mounting screws (10) evenly in several steps. Ensure that the screws do not project after the excitation system (ES) has been mounted to the housing (2) (see maximum thread reach of mounting screws (10) specified in Table 20/1). Ensure that the mounting screws (10) are securely locked. This can be achieved by using microencapsulated screws that comply with the requirements of DIN 267-27. The M_A tightening torques (see Table 20/1) must be strictly observed. Use a torque wrench to tighten the screws.

IMPORTANT



Tighten the set screws (8) evenly in several steps. Ensure that the screws do not project from the circumference of the flange hub (5) after the armature system (AS) has been mounted. Ensure that the set screws (8) are securely locked. This can be achieved by using microencapsulated screws that comply with the requirements of DIN 267-27. The M_A tightening torques (see Table 20/1) must be strictly observed. Use a torque wrench to tighten the screws.

	Brake size											
	03	04	05	06	07	08	09	10	11	14	16	21
Max. thread reach [mm]	3.5	3.5	5.5	5.5	7	5.4	5.9	9.5	9.5	9.5	14	14
Tapped holes for mounting screws (10)	M3	M3	M4	M4	M4	M4	M5	M6	M6	M8	M5 M8	M8
M _A tightening torque [Nm] for mounting screws (10)	1.2	1.2	3	3	3	3	5	9	9	24	5 24	24
Tapped holes for set screws (8)	M3	M3	M4	M4	M5	M5	M6	M6	M10	M10	M10	M12
M _A tightening torque [Nm] for set screws (8)	0.9	0.9	2	2	4	4	7	7	33	33	33	52
Length L ₁ of flange hub (5) [mm] (types 86 611..P00)	-	26.7 _{-0.1}	34.5 _{-0.1}	34.4 _{-0.1}	41 _{-0.1}	35.8 _{-0.1}	37.9 _{-0.1}	51.9 _{-0.1}	52.2 _{-0.1}	56.5 _{-0.1}	74.5 _{-0.1}	79.5 _{-0.1}

Table 20/1: Tapped holes for mounting screws (10) and set screws (8); M_A tightening torques for mounting screws (10) and set screws (8) and max. thread reach of mounting screws (10) (property class 8.8); tolerance of tightening torques ±10%; length L₁ of flange hub (5)



WARNING



Hazards from reduced braking effect due to failure to observe the specified M_A tightening torques when installing the excitation system (ES) and armature system (AS)!

- Uncontrolled movements of the machine shaft (e.g. motor shaft) (12) may cause injury hazards if persons are present within the confines and/or working range of the installation.
- Uncontrolled **extremely fast** movements of the machine shaft (e.g. motor shaft) (12) may cause death if persons are present within the confines and/or working range of the installation.
- The M_A tightening torques specified for the mounting screws (10) and set screws (8) (see Table 20/1) must be strictly observed. Tighten the mounting screws (10) and set screws (8) evenly in two separate steps. In the first step, tighten the mounting screws (10) and set screws (8) evenly, applying about 10% of the specified M_A tightening torque (see Table 20/1). In the second step, tighten the mounting screws (10) and set screws (8) evenly, applying the total M_A tightening torque (see Table 20/1). Avoid any deformation of the housing (2) during brake installation (e.g. caused by excessive tightening of the mounting screws (10)).



WARNING



Hazards from brake failure resulting from incorrect installation of the excitation system (ES) and armature system (AS)!

- Uncontrolled movements of the machine shaft (e.g. motor shaft) (12) may cause injury hazards if persons are present within the confines and/or working range of the installation.
- Uncontrolled **extremely fast** movements of the machine shaft (e.g. motor shaft) (12) may cause death if persons are present within the confines and/or working range of the installation.
- Secure the mounting screws (10) and set screws (8) with a thread locker to DIN 267-27. Ensure that the pole faces are kept free of adhesive residues or similar substances at all times, especially during brake operation at the maximum permissible speed n_{max} (see Table 46/1). Check that the set screws (8) do not project from the tapped holes of the flange hub (5). Ensure that the effective thread length of the set screws (8) enables reliable transmission of the M_A tightening torque (see Table 20/1) on a long-term basis. If necessary, the machine shaft (e.g. motor shaft) (12) must be adjusted in such a way that any projection of the set screws (8) is avoided (e.g. necking of the shaft (12)).
- Ensure that the excitation system (ES) and armature system (AS) are mounted correctly and with maximum care.

NOTICE



Risk of damage to the brake or mounting screws (10) and set screws (8) due to failure to observe the specified M_A tightening torques!

- Putting into service of the High Torque brake and machine (e.g. motor) may not be possible.
- Potential malfunction of the High Torque brake and machine (e.g. motor).
- Potential reduction of the service life of the High Torque brake.
- The M_A tightening torques specified for the mounting screws (10) and set screws (8) (see Table 20/1) must be strictly observed. Tighten the mounting screws (10) and set screws (8) evenly in several steps. Check that the thread reach of the screws is as specified in Table 20/1.
- Avoid any deformation of the housing (2) during brake installation (e.g. caused by excessive tightening of the mounting screws (10)).

NOTICE



Risk of brake damage caused by incorrect dimensions of the set screws (8)!

- Potential malfunction of the High Torque brake.
- Potential malfunction of the machine (e.g. motor).
- Potential breakage or loosening of the set screws (8).
- Check that the set screws (8) are not too long to prevent contact with the flange (3) (only types 86 611..P00) or with stationary machine parts (e.g. motor parts) during brake operation.

NOTICE



Risk of damage to the wire leads (1.3) in case of incorrect brake assembly!

- Putting into service of the High Torque brake and machine (e.g. motor) may not be possible.
- During machine installation, the wire leads (1.3) of the field coil (1.2) must be connected as specified by the manufacturer of the machine (e.g. motor). Avoid damage to the wire leads (1.3), e.g. by kinking the lead insulation.

IMPORTANT



During brake installation, check that all parts are axially secured and that axial bearing play is eliminated. The inner ring of the ball bearing (13) (e.g. motor bearing) must be kept preloaded by using suitable mechanical parts. Make sure that lubricants and similar substances cannot seep from the ball bearing (13) (e.g. motor bearing) into the brake. (Sealed bearings can be used to prevent lubricant leaks.) The assembled brake components, especially the surfaces involved in the friction process, must be free of grease and oil. During installation of the armature system (AS), deformation of the segment springs (7) must be avoided. The air gap must not be larger or smaller than the rated air gap s_N (see Table 46/1 – Technical specifications). An opening (B, see Fig. 15/1 and Fig. 17/1) can be provided in the machine housing (e.g. motor housing) (15) to insert a feeler gauge (see Section 9) in order to measure the air gap 's' between the housing (2) and armature (4) (see Section 5.1 – Maintenance and checks).

4.1.1 Mechanical installation of brake types 86 611..K00 with armature type 300

Installation of the excitation system (ES):

To install the brake excitation system (ES), centre the excitation system (ES) over the outside diameter of the housing (2) at the centring point (Z) (see Fig. 15/1) of the mounting surface (11) on the machine end shield (e.g. motor end shield) (14). Then secure the excitation system (ES) to the mounting surface (11) of the machine end shield (e.g. motor end shield) (14) from the rear side using the mounting screws (10) (see Fig. 15/1).

IMPORTANT



Strictly adhere to the instructions and safety information provided in Section 4.1 when installing the excitation system (ES).

Installation of the armature system (AS) and manual adjustment of the rated air gap s_N :

Slip the armature system (AS) over the machine shaft (e.g. motor shaft) (12) up to the stop shoulder of the machine shaft (e.g. motor shaft) (12). Then secure the flange hub (5) to the machine shaft (e.g. motor shaft) (12) by means of three set screws (8) (see Fig. 15/1).

IMPORTANT



The machine shaft (e.g. motor shaft) (12) and machine end shield (e.g. motor end shield) (14) must be dimensioned in such a way that the rated air gap s_N (see Table 46/1 – Technical specifications) is automatically adjusted when the machine end shield (e.g. motor end shield) (14) with assembled excitation system (ES) is installed. If necessary, shim rings (not shown) can be inserted between the contact surface of the machine shaft (e.g. motor shaft) (12) and the flat face of the flange hub (5).

IMPORTANT



Strictly adhere to the instructions and safety information provided in Section 4.1 when installing the armature system (AS).

Incorporation of the entire brake assembly into the machine (e.g. motor):

After the excitation system (ES) and armature system (AS) have been installed, the entire brake assembly is incorporated into the machine (e.g. motor) in accordance with the instructions provided by the manufacturer of the machine (e.g. motor). This step is part of the final machine assembly procedure (installation of the machine shaft (e.g. motor shaft) (12)).

Before assembling the machine (e.g. motor), the field coil (1.2) of the excitation system (ES) must be connected to a smoothed DC power source (rated voltage of the brake as specified on rating plate (9)) in order to prevent damage to the armature system (AS) during overall assembly.

IMPORTANT



An opening (B, see Fig. 15/1) can be provided in the machine housing (e.g. motor housing) (15) to insert a feeler gauge (see Section 9) in order to measure the air gap 's' between the housing (2) and armature (4) (see Section 5.1 – Maintenance and checks). To check the air gap 's', the High Torque Brake must be released electromagnetically (see Section 4.2 – Electrical connection and operation).

4.1.2 Mechanical installation of brake types 86 611..P00 with armature type 800

The mechanical installation of the armature system (AS) and excitation system (ES) of brake types 86 611..P00 with armature type 800 is performed in a single procedure.

Before installing the excitation system (ES), the field coil (1.2) of the excitation system (ES) must be connected to a smoothed DC power source (rated voltage of the brake as specified on rating plate (9)) in order to prevent damage to the armature system (AS) during overall assembly.

Installation of the armature system (AS) and excitation system (ES):

- Slip the armature system (AS) over the machine shaft (e.g. motor shaft) (12) up to the stop shoulder of the machine shaft (e.g. motor shaft) (12).
- Then secure the flange hub (5) to the machine shaft (e.g. motor shaft) (12) by means of three set screws (8) (see Fig. 15/1).
- Push the excitation system (ES) in axial direction and centrically to the machine shaft (e.g. motor shaft) (12) up to the armature (4) of the armature system (AS). Then disconnect the field coil (1.2) from the DC power source.
- Press the ball bearing (13) of the machine (e.g. motor) firmly onto the machine shaft (e.g. motor shaft) (12) up to the stop on the flange hub (5) according to the instructions provided by the manufacturer of the machine (e.g. motor). If necessary, secure it axially, e.g. with a circlip (see Fig. 17/1).

IMPORTANT



If necessary, a centring pin (see Fig. 23/1, a)) or a centring sleeve (see Fig. 23/1, b)) can be used to centre the excitation system (ES) between the inside or outside diameter of the housing (2) (see offer drawing of relevant component) and the motor shaft (12).

Centring the excitation system (ES)

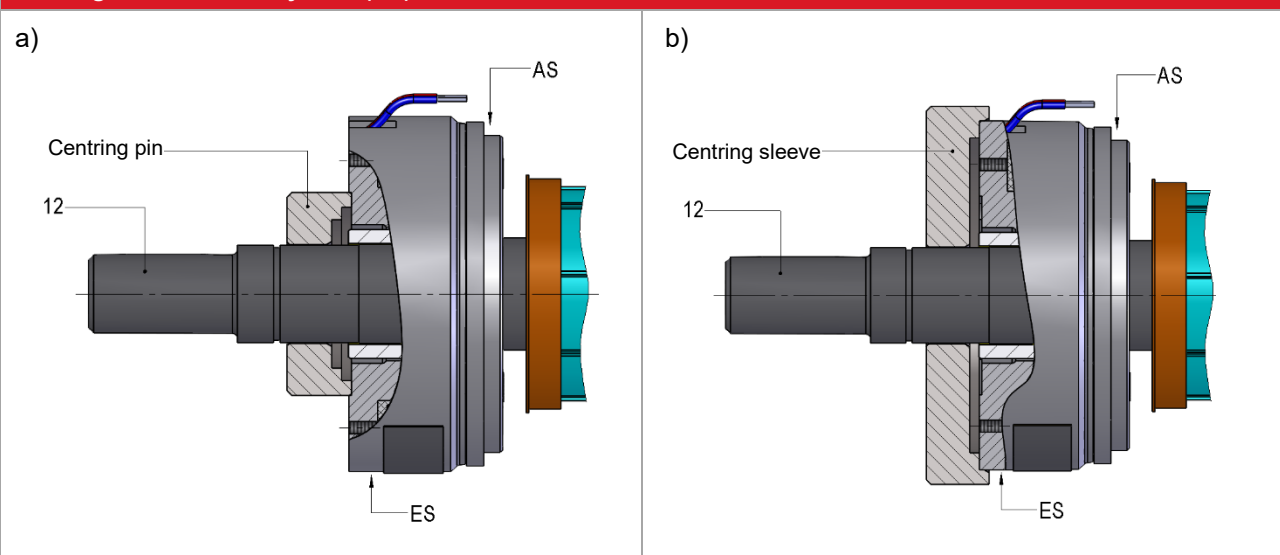

Fig. 23/1: High Torque brake types 86 611..P00 with armature type 800
 a) Centring via centring pin on inside diameter of housing (2)
 b) Centring via centring sleeve on outside diameter of housing (2)

IMPORTANT



Strictly adhere to the instructions and safety information provided in Section 4.1 when installing the armature system (AS).

Incorporation of the entire brake assembly into the machine (e.g. motor):

After the excitation system (ES) and armature system (AS) have been installed, the entire brake assembly is incorporated into the machine (e.g. motor) in accordance with the instructions provided by the manufacturer of the machine (e.g. motor). This step is part of the final machine assembly procedure (installation of the machine shaft (e.g. motor shaft) (12).

Before the machine end shield (e.g. motor end shield) (14) is firmly secured in place, preliminary centring of the brake must be performed on the centring point (Z) (see Fig. 17/1) via the outer diameter of the housing (2).

IMPORTANT



After pre-centring the brake, connect the field coil (1.2) of the excitation system (ES) to a smoothed DC power source (rated voltage of the brake as specified on rating plate (9)).

Use the mounting screws (10) to secure the brake to the mounting surface (11) of the machine end shield (e.g. motor end shield) (14) from the rear side (see Fig. 17/1). Ensure that the screws are firmly tightened.

IMPORTANT



Strictly adhere to the instructions and safety information provided in Section 4.1 when installing the brake and excitation system (ES) to the mounting surface (11).

IMPORTANT



When using High Torque brake types 86 611..P00 with armature type 800, the ball bearing (13) is secured axially to the machine end shield (e.g. motor end shield) (14) via the housing (2) of the excitation system (ES). A small gap remains between the housing (2) and the mounting surface (11) of the machine end shield (e.g. motor end shield) (14) after completion of assembly.

4.2 Electrical connection and operation

4.2.1 Electrical connection of the High Torque brake

The High Torque brake must be connected directly to a smoothed DC power source, connecting the wire leads (1.3) to the power supply with the correct polarity (see Table 25/1). The power supply specifications on the rating plate (9) must be observed. Connection to an AC power source is only possible by means of bridge rectifiers. A special Kendrion rectifier type (see Table 25/2 (list not exhaustive)) can be provided for this purpose, if required.

Wire leads	Polarity
Blue wire lead (1.3) of brake	-
Red wire lead (1.3) of brake	+

Table 25/1: Polarity of wire leads

IMPORTANT



The correct polarity of the wire leads is crucial to ensure reliable operation of the High Torque brake (see Table 25/1). During operation, any contact of the wire leads (1.3) with the rotating armature (4) or other rotating parts must be avoided. Depending on the brake size and torque, voltage ripple due to intermittent power supply may cause humming or incorrect brake operation. Reliable operation must be ensured by the user or system manufacturer by providing suitable electrical controls.

Rectifier series	Rectifier type	Rated input voltage range $U_1 (\pm 10\%)$ [VAC] (40 – 60 Hz)	Output voltage U_2 [VDC]	Max. output current I_2 [ADC]
32 07.23B.0	bridge	0 – 400 ($\pm 10\%$)	$U_1 \cdot 0.890$	2.0
32 07.03B0.	bridge	0 – 500 ($\pm 10\%$)	$U_1 \cdot 0.890$	2.0
The relevant rectifier specification sheets must be observed!				

Table 25/2: Recommended rectifiers for single-phase AC voltage supply

Perform the following checks when connecting the brake:

- Check that the connecting cables are suitable for the intended use and for the voltage and amperage requirements.
- Check that the connecting cables are secured with screws, clamps or other suitable fixtures to avoid interruptions in the power supply.
- Check that the connecting cables are long enough for the intended use and that suitable torsion, strain and shear relief features as well as bending protections are provided.
- Check that the PE conductor (only for protection class I) is connected to the earthing point.
- Check that no foreign matter, dirt or humidity is trapped inside the terminal box of the machine (e.g. motor).
- Check that unused cable entries and the terminal box (if present) of the machine (e.g. motor) or brake are suitably sealed to ensure compliance with the protection class requirements to EN 60529.



DANGER



Electricity hazards from incorrect electrical connection of the component!

- Fatal electric shock hazard.
- All work must be performed by qualified specialist personnel only. Check that no voltage is present when connecting the component to the power supply. The specifications on the rating plate and the information provided in the circuit diagram, which (if available) may be located in the terminal box of the machine (e.g. motor) or in the operating instructions, must be strictly observed.

NOTICE



Risk of damage to the field coil (1.2) from incorrect electrical connection of the component!

- Release of the High Torque brake may no longer be possible.
- Putting into service of the High Torque brake and machine (e.g. motor) may not be possible.
- The brake is a DC operated system. The permissible permanent voltage variations on the power source of the electromagnetic brake are specified in Table 46/2.

4.2.2 DC power supply

The figure to the right shows the voltage and torque curves after the field coil (1.2) has been de-energized without protective circuit (time t_{c1} specified in Section 10).

NOTICE



Risk of damage to or destruction of the brake field coil (1.2) from overvoltage!

- Release of the High Torque brake may no longer be possible.
- Potential malfunction of the machine (e.g. motor).
- The peak voltage U_{Vmax} during turn-off without protective circuit may reach **several thousand volts** in the millisecond region. This may cause irreversible damage to the field coil (1.2), switching contacts and electronic components. Sparking will occur on the switch during turn-off. Consequently, a protective circuit must be provided to reduce the current during turn-off and to limit the voltage. The maximum permissible overvoltage during turn-off is 1500 V.

Voltage and torque curves

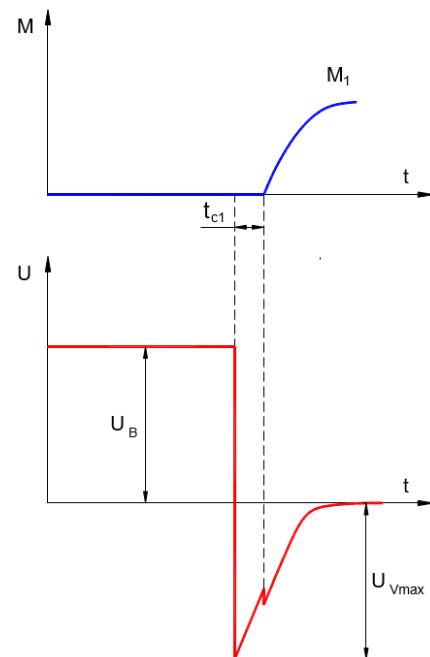

U_B operating voltage (coil voltage)
 U_{Vmax} turn-off voltage

NOTICE



Risk of damage to or destruction of electronic components from overvoltage!

- Release of the High Torque brake may no longer be possible.
- Potential malfunction of the machine (e.g. motor).
- The maximum permissible overvoltage during turn-off is 1500 V. If Kendrion rectifiers are used (see Table 25/2), the protective circuit required for the built-in electronic components and field coil (1.2) is included in the rectifier. This does not apply to the external contacts required for DC side switching as there would be no galvanic isolation of the external contact. Sensitive electronic components (e.g. logical components) may also be damaged at a lower voltage.

AC side switching with DC power supply:

AC side switching of the brake is achieved by using a free-wheeling diode without additional protective elements against overvoltage. With this type of circuitry, no or only very low turn-off voltage occurs during turn-off. However, when operating the High Torque brake in this way, bear in mind that the closing times t_{c1} (see Table 46/1, definition in Section 10) of the brake are extended due to the use of the free-wheeling diode. The opening times t_o (see Table 46/1, definition in Section 10) are not extended.

DC side switching with DC power supply:

In case of DC side switching of the brake without a free-wheeling diode, the power supply to the brake is interrupted directly, e.g. by a switch. If no additional protective elements are used, very high turn-off voltage may occur with this type of circuitry. Therefore, DC side turn-off is only possible when protective elements are used for voltage limitation (see Fig. 28/1). When the High Torque brake is operated in this manner, bear in mind that the significant reduction of the electric time constant causes the brake to engage quickly and the switching noise to increase (see Section 7 – Emissions).

NOTICE



Risk of damage to or destruction of electronic components and the brake field coil (1.2) if protection measures are insufficient or inadequate!

- Release of the High Torque brake may no longer be possible.
- Potential malfunction of the machine (e.g. motor).
- In case of DC side switching, the brake must be provided with a protective circuit to avoid overvoltage (see Section 4.2.2). Additional protective elements (e.g. varistors, spark arresters etc.) must be installed to avoid damage such as burns or fusing of contacts to external circuitry. (Circuit example and electrical components for protective circuitry: see Table 27/1 and Fig. 28/1)

Ref.	Designation	Ref.	Designation	Ref.	Designation
①	Field coil (1.2)	②	Free-wheeling diode	③	Varistor type S10K30 (for power supply up to 24 VDC)
S	Switch				

Table 27/1: Electrical components and recommended varistors for external protective circuitry in case of DC side switching of the brake and direct connection of the field coil (1.2) to a DC power source

Protective circuitry for DC power supply

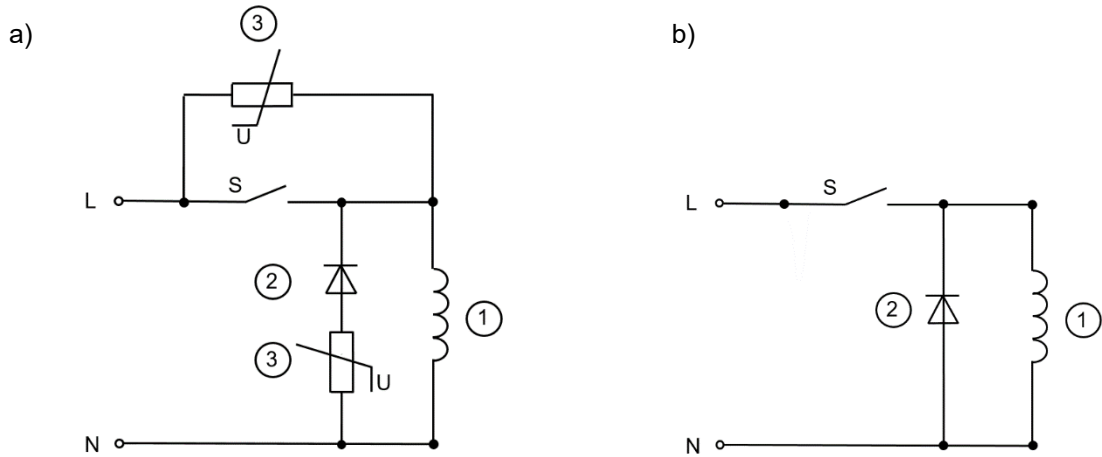

Fig. 28/1: DC side and AC side switching of the High Torque brake with direct connection of the field coil (1.2) to a DC power source (example)

- a) DC side switching and direct connection of the field coil (1.2) to a DC power source with recommended protective circuitry
- b) AC side switching and direct connection of the field coil (1.2) to a DC power source with free-wheeling diode, but without additional protective circuitry

4.2.3 AC power supply

Direct brake connection to an AC power source is only possible if a rectifier is used. The closing times t_{c1} (as defined in Section 10) vary depending on the switching type (DC side switching or AC side switching).

Bridge rectification:

Bridge rectifiers provide voltage with minimum residual ripple. This means that brake humming can be avoided even if small size brakes are used. In case of bridge rectification, the U_2 coil voltage is lower by factor 0.89 than the rectifier input voltage U_1 .

Circuitry variants for AC power supply

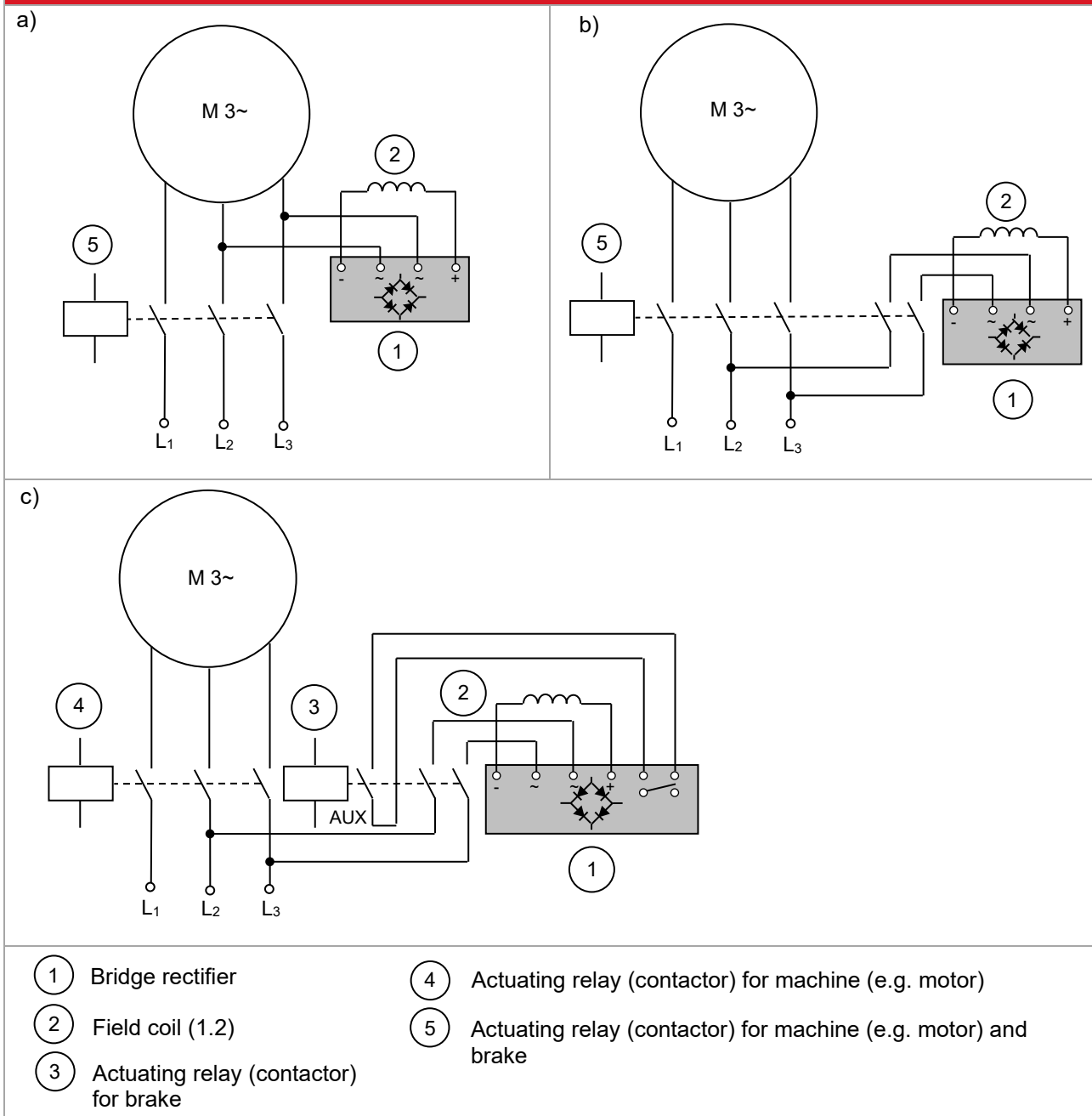

Fig. 29/1: DC side and AC side switching of the High Torque brake with connection of the field coil (1.2) to an AC power source via a bridge rectifier (example)

- a) AC side switching and connection of the bridge rectifier to an AC power source in parallel with the machine (e.g. motor)
- b) AC side switching and direct connection of the bridge rectifier to an AC power source
- c) DC side switching with additional auxiliary contact (AUX) and direct connection of the bridge rectifier to an AC power source

AC side switching with AC power supply:

The easiest wiring method is to connect the rectifier in parallel with the brake in the terminal box of the machine (e.g. motor) (see Fig. 29/1, a)). It must be considered, however, that the motor may act as a generator after AC voltage has been removed and thus extend the closing times t_{c1} (see definitions in Section 10) significantly (by factor 5 or over). The opening times t_o (see definitions in Section 10) remain unchanged.

DC side switching with AC power supply:

In case of DC side brake switching, an auxiliary contact is provided to interrupt the power supply on the DC side (brake side) (see Fig. 29/1, c)). When the High Torque brake is operated in this manner, bear in mind that the significant reduction of the electric time constant causes the brake to engage quickly and the switching noise to increase (see Section 7 – Emissions).

NOTICE



Risk of damage to or destruction of electronic components and the brake field coil (1.2) if protection measures are insufficient or inadequate!

- Release of the High Torque brake may no longer be possible.
 - Potential malfunction of the machine (e.g. motor).
- When using bridge rectifiers without internal protective circuitry elements and in case of DC side switching, the brake must be operated with a protective circuit to avoid overvoltage (see Section 4.2.2). Additional protective elements (e.g. varistors, spark arresters etc.) must be installed to avoid damage such as burns or fusing of contacts to external circuitry. (Circuit example and electrical components for protective circuitry: see Table 30/1 and Fig. 30/1)

Protective circuitry for AC power supply

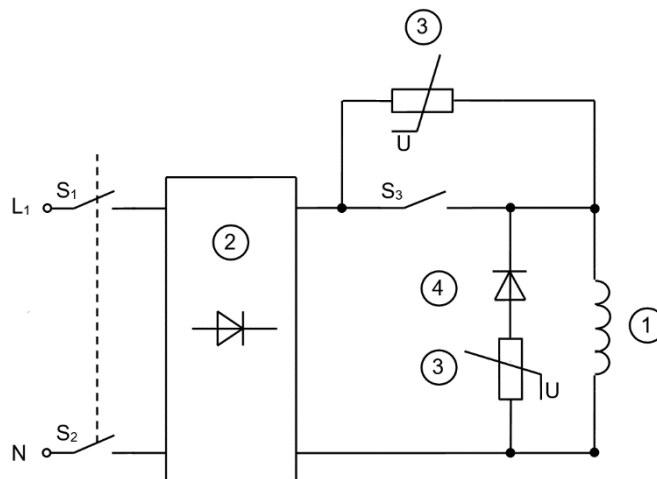

Fig. 30/1: Circuit examples for recommended protective measures for DC side switching of the High Torque brake when the field coil (1.2) is connected to an AC power source via a bridge rectifier without internal protective circuitry elements

Ref.	Designation	Ref.	Designation
①	Field coil (1.2)	③	Varistor type S10K550 (for power supply up to 400 VAC)
②	Bridge rectifier (without internal protective circuitry)	④	Free-wheeling diode
S ₁ .. S ₃	Switch		

Table 30/1: Electrical components and recommended varistors for external protective circuitry in case of DC side switching of the brake and connection of the field coil (1.2) to an AC power source via a bridge rectifier

4.3 Electromagnetic compatibility

As required by the German Electromagnetic Compatibility Act (EMVG), electromagnetic compatibility is essential to ensure immunity to external electromagnetic fields and conducted interference. Furthermore, the emission of electromagnetic fields and line-conducted interference during brake operation must be minimized. Since the brake features depend on the circuitry and operation, a declaration of conformity with the applicable EMC standard can only be furnished for the wiring type, but not for a specific brake. The High Torque brake types 86 611..P00 and 86 611..K00 are designed for industrial applications to which the following EMC standards apply: Generic Immunity Standard EN 61000-6-2 and Generic Emission Standard EN 61000-6-3 / EN 61000-6-4. Other applications may be subject to different generic standards which must be considered by the manufacturer of the installation. The requirements in terms of electromagnetic compatibility of devices and components are determined by basic standards derived from the generic standards. Wiring recommendations will be provided in the following sections to ensure compliance with the individual basic standards that are relevant for industrial use and other applications. Please refer to the relevant specification sheets for additional information on electromagnetic compatibility, especially with respect to the recommended electronic rectifiers specified in Section 4.2.1.

Immunity according to EN 61000-4:

EN 61000-4-2 Electrostatic discharge:

The High Torque brake types 86 611..P.. and 86 611..K.. comply at least with severity level 3 without requiring additional measures. The recommended rectifiers specified in Section 4.2.1 conform to severity level 3 without additional measures.

EN 61000-4-3 Electromagnetic fields:

The brakes comply at least with severity level 3 without requiring additional measures. The recommended rectifiers conform to severity level 3 without additional measures.

EN 61000-4-4 Fast transients (burst):

The brakes comply at least with severity level 3 without requiring additional measures. The recommended rectifiers conform to severity level 3.

EN 61000-4-5 Surge:

The brakes comply at least with severity level 3 without requiring additional measures. The recommended rectifiers conform to severity level 3.

EN 61000-4-9 Pulse magnetic fields, EN 61000-4-10 Damped oscillatory magnetic fields:

Since the operating magnetic fields of the electromagnetic brakes are stronger many times over than interference fields, the brake function will remain unaffected. The brakes comply at least with severity level 4. The recommended rectifiers conform at least to severity level 3.

EN 61000-4-11 Voltage dips, short interruptions, and short supply voltage variations:

a) Voltage interruptions:

Brakes that comply with the requirements of DIN VDE 0580 are de-energized after the specified switching times at the latest. The switching time depends on the control and mains conditions (e.g. generator effect of running down motors). Voltage interruptions of shorter duration than the response delay specified by DIN VDE 0580 will not cause any malfunctions. The user is required to take adequate precautions to avoid consequential damage. The functional reliability of the electromagnetic component and its electronic accessories remains unaffected if consequential damage is avoided.

b) Voltage dips and short supply voltage variations:

Electromagnetically released systems:

Voltage dips and supply voltage variations to below 60% of the rated voltage and lasting longer than the response delay specified by DIN VDE 0580 may cause the brake to be de-energized temporarily. Consequential damage must be avoided by the user by taking adequate precautions.

Electromagnetically engaged systems:

Voltage dips and supply voltage variations to below the minimum tolerance threshold will cause torque reductions. The user is required to take adequate precautions to avoid consequential damage.

Radio interference suppression in accordance with EN 55011:

The brakes and the recommended electronic rectifiers are classified as Group 1 equipment in accordance with EN 55011. As far as the emissions from this equipment are concerned, one distinguishes between field guided radiated interference and line-conducted interference.

a) Radiated interference:
When operated with DC voltage or rectified 50/60 Hz AC voltage, all brakes comply with the limit values applicable to Class B equipment.

b) Conducted interference:
When connected to a DC power source, the electromagnetic brakes meet the limit values applicable to Class A equipment. If the brakes are connected to a 50/60 Hz AC power source and equipped with electronic rectifiers or other electronic controls, interference suppression measures as shown in Fig. 32/1 must be taken to ensure compliance with the limit values applicable to Class A equipment. Interference suppression capacitors should be used which must be dimensioned to suit the connection data of the electromagnetic components and the specific mains conditions. The recommended rectifiers specified in Section 4.2.1 are CE mark certified in accordance with the EMC Directive. They have built-in interference suppression components and comply at least with the requirements of EN 55011 for Class A equipment, unless otherwise specified in the specification sheet. Interference suppression components should be installed as close as possible to the consumer. Interference caused during switching operations of the electromagnetic component is generally attributable to the inductive load. Where necessary, devices designed to limit the turn-off voltage (e.g. anti-parallel diode) or voltage limiting components (e.g. varistors, suppressor diodes, resistance diodes and the like) can be installed. However, such components will inevitably change the switching times of the brake and increase the generated noise level. The rectifiers specified in Section 4.2.1 are equipped with free-wheeling diodes and/or varistors to limit the turn-off voltage. In case of DC side switching, a varistor rated for the type-specific maximum operating voltage and connected in parallel with the field coil (1.2) limits the peak voltage to the values specified in Table 32/1.

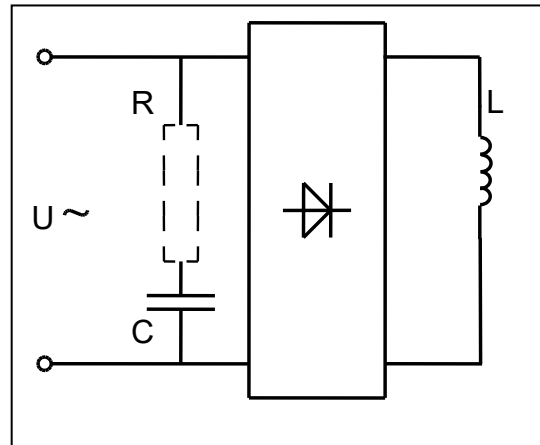

Fig. 32/1

If the brake is used in connection with other electronic accessories, the user is responsible to ensure compliance with EMC requirements. Compliance with applicable standards concerning the design and operation of components, sub-assemblies or equipment employed will not relieve the user and manufacturer of the installation from their obligation to furnish proof of conformity of the installation with such standards.

Max. rectifier operating voltage [VAC]	Recommended turn-off voltage in case of DC side switching [V]
250	700
440	1200
550	1500

Table 32/1: Recommended turn-off voltage in case of DC side switching for rectifiers specified in Table 25/2

4.4 Putting into service

Check compliance with the specifications provided on the rating plate (9) with respect to the mounting position and protection class. Before putting the brake into service, perform a functional test to check the free movement of the armature system (AS), e.g. by turning the machine shaft (e.g. motor shaft) (12) with energized brake and unpowered machine (e.g. motor). After completion of assembly, all necessary covers and guards must be installed. At the end of the installation procedure or whenever necessary (e.g. after a prolonged storage period), a break-in process is required in accordance with the parameters specified in Table 47/1 and Table 47/2.

IMPORTANT



For functional testing, the brake should be released electrically via a separate power source. After completion of the functional tests, connect the brake to the power source as described in Section 4.2.

Specifications on the rating plate (subject to order, example brake type 86 61116P00):

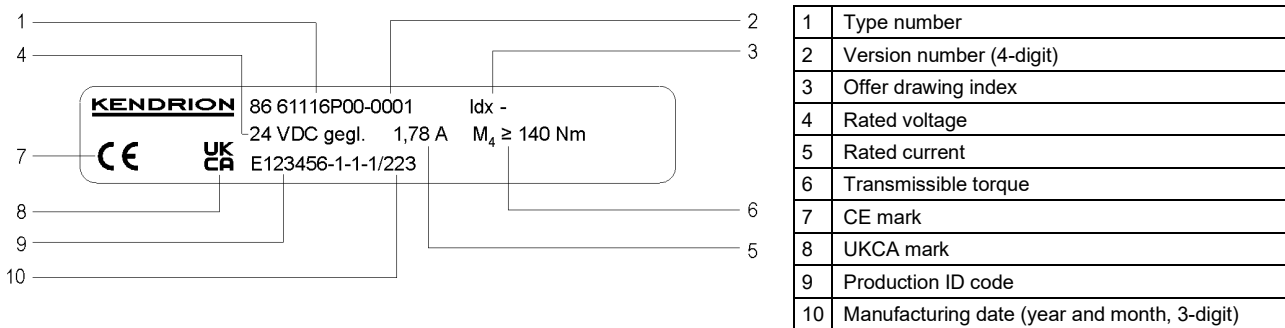

Note: The product number of the High Torque brake consists of the type number followed by the version number, e.g. 86 61116P00-0001.



DANGER



Electricity hazards from incorrect electrical connection of the component!

- Fatal electric shock hazard.
- All work must be performed by qualified specialist personnel only. Check that no voltage is present before connecting the component to the power supply. The specifications on the rating plate and the information provided in the circuit diagram, which (if available) may be located in the terminal box of the machine (e.g. motor) or in the operating instructions, must be strictly observed.



CAUTION



Hazards from contact with rotating parts (e.g. armature system (AS), machine shaft (e.g. motor shaft) (12) etc.) during operation of the brake and/or machine (e.g. motor)!

- Physical injury hazard (e.g. chafing, cuts etc.) to hands and limbs.
- Functional testing of the brake must not be performed unless the machine (e.g. motor) has been turned off and secured so that it cannot be turned back on inadvertently or by unauthorized persons. Do not touch rotating parts (e.g. armature system (AS), machine shaft (motor shaft) (12) etc.).



CAUTION



Hazards from contact with loose parts during operation of the brake and/or machine (e.g. motor)!

- Physical injury hazard (e.g. cuts etc.) to limbs and other parts of the body.
- Before starting the test run of the machine (e.g. motor) without driven components, the feather key (if used) must be secured in such a way that it cannot be hurled out. The machine shaft (e.g. motor shaft) (12) must not be exposed to load torques. Ensure that the brake is unpowered before restarting the machine.



CAUTION



Hazards from contact with hot parts during brake operation!

- Injury hazard (e.g. skin burns) to hands, limbs and other parts of the body.
- Depending on the operating state of the brake, its surface temperature may rise to over 60°C. If necessary, suitable protections and hand guards must be installed to avoid accidental contact with hot surfaces.
- Wear protective gloves, if necessary.

NOTICE



Risk of property damage caused by hot parts during brake operation!

- Release of the High Torque brake may no longer be possible.
- Irreversible damage to heat-sensitive parts (e.g. cables) may occur.
- Putting into service of the High Torque brake and machine (e.g. motor) may not be possible.
- The brake surface temperature may rise to over 60°C. Heat-sensitive parts such as conventional cables or electronic components must not be fixed to or be in contact with hot surfaces.

NOTICE



Risk of damage to or destruction of the brake field coil (1.2) if the high-voltage test is not performed correctly!

- Release of the High Torque brake may no longer be possible.
- Putting into service of the High Torque brake and machine (e.g. motor) may not be possible.
- High-voltage tests performed when mounting the brake in an installation or when putting the brake into service must be carried out in such a way that damage to the built-in electronic accessories is avoided. The limits for high-voltage tests and follow-up tests specified in DIN VDE 0580 must be observed.

NOTICE



Risk of damage to the field coil (1.2) from incorrect electrical connection of the component!

- Release of the High Torque brake may no longer be possible.
- Putting into service of the High Torque brake and machine (e.g. motor) may not be possible.
- Check that the brake has been connected in accordance with the specifications provided on the rating plate (9) before it is put into service. Even short-term operation outside the specified supply voltage limits may cause irreversible damage to the brake or electronic accessories. Such damage may not be apparent immediately. DC side brake switching without protective circuit as described in Section 4.2.2 will cause early damage to electronic rectifiers, electronic accessories, switching contacts and the field coil (1.2) not designed for this purpose.

IMPORTANT



Magnetic interference fields have an impact on magnetically conductive components (machine shaft (e.g. motor shaft) (12) or other parts) and thus affect the way the High Torque brake behaves during release and braking. In such cases, the magnetic specifications of the brake must be factory-adjusted to the specific installation conditions.

5. Maintenance, repair and replacement

5.1 Maintenance and checks

The High Torque brakes are generally maintenance-free over the entire service life. Any tests conducted to confirm the correct function, operational safety and reliability of the brakes must be performed during the regular inspection and service of the machine (e.g. motor). The tests, test procedures and test criteria are specified in Table 36/1, Table 36/2 and Table 37/1.

Required tests:

Air gap 's' (see Fig. 15/1 and Fig. 17/1)

Test procedures / criteria	<p><u>Checking the air gap 's' of the brake:</u></p> <p>For a quick check of the air gap 's' of the installed brake, an opening (B, see Fig. 15/1 or Fig. 17/1) should be provided in the machine housing (e.g. motor housing) (15) in the area of the brake housing (2) and armature (4). When the brake is disengaged, a feeler gauge (see Section 9) can be used to measure the air gap 's' on the circumference of the brake between the housing (2) and the armature (4).</p>
	<p><u>Test criterion:</u></p> <p>The measured air gap 's' must not exceed the limit values specified for the operating air gap s_B (see Table 46/1).</p>

IMPORTANT

- i** When the maximum operating air gap s_{Bmax} is reached (see Table 46/1), the brake **must** be replaced (see Section 5.2). Brake replacement is also necessary when defects are suspected. To remove the brake for replacement, follow the instructions in Section 5.2. To install the new brake and put it into service, proceed as described in Sections 4 and 4.4 respectively.

Table 36/1: Checking the air gap 's' of the brake

Switching function of High Torque brake

Test procedures / criteria	<p><u>Assessment of brake release and engagement:</u></p> <p>To assess the functionality of the brake, the reliable and safe release and engagement of the brake must be tested as part of the functional test of the machine (e.g. motor).</p>
	<p><u>Test criterion:</u></p> <p>Brake release: Brake operation with a supply voltage within the permissible voltage range (see Table 46/2). Check that the brake is fully released. Check that the machine shaft (e.g. motor shaft) (12) moves freely without restriction.</p> <p>Brake engagement: Power supply (supply voltage) turned off. Check that the brake is fully engaged. Check that the machine shaft (e.g. motor shaft) (12) is firmly locked.</p>
	<p><u>Note:</u></p> <p>The switching function can be checked by manually moving the machine shaft (e.g. motor).</p>

IMPORTANT

- i** If correct brake release and engagement is not possible or if defects are suspected, the brake **must** be replaced. A new High Torque brake must be installed as described in Section 4. To put the new brake into service, follow the instructions in Section 4.4.

Table 36/2: Checking the switching function of the brake

Further recommended checks to be performed within the brake service life during service or maintenance of the machine (e.g. motor):

Electrical connection and overall appearance

Test procedures / criteria	<p><u>Checking the electrical connection:</u> Perform a visual inspection of the power connections of the brake.</p> <p><u>Test criterion:</u> Complete absence of damage or defects to the power connections (wire leads (1.3)).</p>
	<p><u>Checking the overall appearance:</u> Perform a visual inspection of the mechanical components of the High Torque brake. If dirt has accumulated in the brake or on the rating plate (9) due to abrasion, foreign matter or other phenomena, clean the affected surfaces with oil-free compressed air or by using a brush.</p> <p><u>Test criterion:</u> Complete absence of damage or defects to the mechanical brake components.</p>

IMPORTANT



The overall appearance of the brake can only be checked after the brake has been removed from the machine (e.g. motor). If defects are suspected, the brake **must** be replaced. A new High Torque brake must be installed as described in Section 4. To put the new brake into service, follow the instructions in Section 4.4.

Table 37/1: Checking the electrical connection and overall appearance

IMPORTANT



During long periods of inaction, the surfaces of the flange (3) and/or housing (2) involved in the friction process may corrode and reduce the brake torque. A short break-in process (see Table 47/1 or Table 47/2) will restore correct and reliable brake operation.



DANGER



Electricity hazards from incorrect electrical connection or disconnection of the component!

- Fatal electric shock hazard.
- All work must be performed by qualified specialist personnel only. Check that no voltage is present before connecting the component to the power supply. The specifications on the rating plate and the information provided in the circuit diagram, which (if available) may be located in the terminal box of the machine (e.g. motor) or in the operating instructions, must be strictly observed.



WARNING



Hazards from insufficient braking effect due to failure to comply with the specified service, maintenance and inspection requirements and intervals!

- Uncontrolled movements of the machine shaft (e.g. motor shaft) (12) may cause injury hazards if persons are present within the confines and/or working range of the installation.
- Uncontrolled **extremely fast** movements of the machine shaft (e.g. motor shaft) (12) may cause death if persons are present within the confines and/or working range of the installation.
- Ensure that the maximum operating air gap s_{Bmax} (see Table 46/1) is not exceeded during operation of the High Torque brake. Therefore, the test intervals must be determined by the manufacturer of the machine (e.g. motor) or by the user of the component in such a way that correct brake operation is ensured throughout the entire service life.
- When the maximum operating air gap s_{Bmax} is reached (see Table 46/1), the brake **must** be replaced (see Section 5.2).



WARNING



Hazards from insufficient braking effect in case of contaminated friction surfaces of brake!

- Uncontrolled movements of the machine shaft (e.g. motor shaft) (12) may cause injury hazards if persons are present within the confines and/or working range of the installation.
- Uncontrolled **extremely fast** movements of the machine shaft (e.g. motor shaft) (12) may cause death if persons are present within the confines and/or working range of the installation.
- Ensure that all surfaces involved in the friction process are free of grease and oil.
- Check that no swelling or glazing of the friction lining (if used) has occurred.



CAUTION



Hazards from contact with rotating parts (e.g. armature system (AS), machine shaft (e.g. motor shaft) (12) etc.) during operation of the brake and/or machine (e.g. motor)!

- Physical injury hazard (e.g. chafing, cuts etc.) to hands and limbs.
- Functional testing of the brake must not be performed unless the machine (e.g. motor) has been turned off and secured so that it cannot be turned back on inadvertently or by unauthorized persons. Do not touch rotating parts (e.g. armature system (AS), machine shaft (e.g. motor shaft) (12) etc.).
- After completion of inspection and maintenance operations, remove the lock provided to prevent accidental start-up of the machine (e.g. motor).

NOTICE



Risk of brake damage due to failure to comply with the specified service, maintenance and inspection requirements and intervals!

- The function and operation of the High Torque brake may be compromised.
- Potential malfunction of the machine (e.g. motor).
- The test intervals must be determined by the manufacturer of the machine (e.g. motor) or by the user of the component in such a way that correct brake operation is ensured throughout the entire service life.
- Any tests conducted to confirm the correct function, operational safety and reliability of the High Torque brake must be performed with extreme caution and by qualified specialist personnel only. The information on the rating plate (9) attached to the brake must be strictly observed during maintenance and when putting the brake back into service.

IMPORTANT



Brake service and maintenance during operation is performed by the manufacturer of the machine (e.g. motor) in accordance with their specific maintenance instructions. The specific maintenance instructions of the machine manufacturer (e.g. motor manufacturer) must take account of the requirements specified in Section 5.1 (Maintenance and checks) of these operating instructions.

5.2 Brake repair and replacement in case of failure

If a failure occurs, the entire High Torque brake has to be replaced by the manufacturer of the machine (e.g. motor). The brake can only be repaired by the brake manufacturer or by specially trained and qualified specialist personnel of the machine manufacturer (e.g. motor manufacturer).

IMPORTANT



Before starting to repair or replace the High Torque brake, dismantle the machine (e.g. motor). To do so follow the instructions provided by the machine manufacturer. Brake replacement must be performed in accordance with the specific maintenance instructions provided by the manufacturer of the machine (e.g. motor). These instructions must take account of the requirements specified in Section 4 (Installation) and Section 5.2 (Brake repair and replacement in case of failure) of this manual.



DANGER



Electricity hazards from incorrect electrical connection or disconnection of the component!

- Fatal electric shock hazard.
- All work must be performed by qualified specialist personnel only. Check that no voltage is present before connecting the component to the power supply. The specifications on the rating plate and the information provided in the circuit diagram, which (if available) may be located in the terminal box of the machine (e.g. motor) or in the operating instructions, must be strictly observed.



DANGER



Hazards from incorrect brake replacement!

- Uncontrolled movements of the machine shaft (e.g. motor shaft) (12) may cause injury hazards if persons are present within the confines and/or working range of the installation.
- Uncontrolled **extremely fast** movements of the machine shaft (e.g. motor shaft) (12) may cause death if persons are present within the confines and/or working range of the installation.
- The machine (e.g. motor) must be turned off by the manufacturer's service and/or maintenance personnel before starting to replace the brake. Brake replacement must not be performed unless the machine (e.g. motor) has been turned off and secured so that it cannot be turned back on inadvertently or by unauthorized persons. Do not touch rotating parts such as the machine shaft (e.g. motor shaft) (12) etc.).

**WARNING****Hazards from insufficient braking effect due to delayed repair or replacement of the component!**

- Uncontrolled movements of the machine shaft (e.g. motor shaft) (12) may cause injury hazards if persons are present within the confines and/or working range of the installation.
- Uncontrolled **extremely fast** movements of the machine shaft (e.g. motor shaft) (12) may cause death if persons are present within the confines and/or working range of the installation.
- Depending on its operating condition, engagement of the High Torque brake may no longer be possible when the maximum operating air gap s_{Bmax} (see Table 46/1) has been exceeded. Replace the entire brake **at the latest** when the maximum operating air gap s_{Bmax} (see Table 46/1) is reached.

Replacement of the High Torque brake:

The brake must be replaced in the event defects or irreparable failures or malfunctions (see Section 8), or – at the latest – when the maximum operating air gap s_{Bmax} (see Table 46/1) is reached.

Follow the instructions below to replace the High Torque brake:

- Before removing the brake, connect the field coil (1.2) of the excitation system (ES) to a smoothed DC power source (rated voltage of brake as specified on rating plate (9)).
- Disconnect the machine end shield (e.g. motor end shield) (14) from the machine housing (e.g. motor housing) (15). Remove the circlip (see Fig. 15/1 or Fig. 17/1) if used to secure the ball bearing (13) to the machine shaft (e.g. motor shaft) (12).
- Pull the complete machine end shield (e.g. motor end shield) (14), including the excitation system (ES) of the component and the ball bearing (13), off the machine housing (e.g. motor housing) (15) (e.g. by using a puller). Then disconnect the field coil (1.2) from the DC power source.
- After loosening the mounting screws (10), remove the excitation system (ES) from the mounting surface (11) of the machine end shield (e.g. motor end shield) (14).
- After having removed the machine shaft (e.g. motor shaft) (12), loosen the set screws (8) and pull the complete armature system (AS) off the machine shaft (e.g. motor shaft) (12) (e.g. by using a puller).

To install the new brake and put it into service, proceed as described in Sections 4 and 4.4 respectively.

5.3 Spare parts and accessories

No spare parts or accessories are available for the High Torque brakes types 86 611..P00 und 86 611..K00.

6. Condition at delivery, transport and storage

The High Torque brake is delivered ready for mounting. The set screws (8) and mounting screws (10) are not included in the brake. Upon receipt of the shipment, the brake must be checked for transit damage before storage. If the brake is not installed immediately upon delivery, it must be stored in a dry, dust-free and vibration-proof place.

	Environmental conditions	
	Conditions for storage to EN IEC 60721-3-1	Conditions for transport to EN IEC 60721-3-2
Mechanical conditions (M)	1M11	2M4
Climatic conditions (K)	1K21 and 1Z2	2K12
Biological conditions (B)	1B1	2B1
Mechanically active substances (S)	1S11	2S5
Chemically active substances (C)	1C1	2C1

Table 41/1: Environmental conditions for storage and transport as specified in EN IEC 60721-3-1 and EN IEC 60721-3-2

IMPORTANT



The environmental conditions specified in Table 41/1 and in EN IEC 60721-3-2 / EN IEC 60721-3-1 must be observed during transport and storage of the brake, especially when long-term storage is envisaged. The specified environmental conditions apply only if the brake is stored in its original packaging.

IMPORTANT



The excitation system (ES) and armature system (AS) of the brake are factory-adjusted to ensure reliable brake release. Consequently, individual component parts cannot be replaced.

7. Emissions

7.1 Noise

The High Torque brake produces switching noise during engagement and release. The noise level is determined by the mounting and installation conditions, circuitry and air gap 's'. Depending on the mounting position, operating conditions and condition of the friction surfaces, audible vibrations (squealing) may occur during braking.

7.2 Heat

Braking operations and gradual heating of the field coil (1.2) cause the brake temperature to increase substantially. Under adverse conditions, the surface temperature may rise to well over 60°C.



CAUTION



Hazards from contact with hot parts during brake operation!

- Injury hazard (e.g. skin burns) to hands, limbs and other parts of the body.
- Depending on the operating state of the brake, its surface temperature may rise to over 60°C. If necessary, suitable protections and hand guards must be installed to avoid accidental contact with hot surfaces.
- Wear protective gloves, if necessary.

8. Troubleshooting

Fault	Cause	Corrective actions
Brake engagement failure	• Air gap 's' too large	Check the air gap 's' (see Section 5.1). Install a new brake, if necessary (see Section 5.2).
	• Voltage applied to brake	Check the power connections (see Section 4.2) and correct faults, if found.
	• Voltage applied to field coil (1.2) too high	Check the supply voltage of the field coil (1.2) and correct faults, if found.
	• Defective rectifier (if used)	Check the rectifier (if used) and replace it, if necessary.
	• Armature (4) blocked mechanically	Eliminate mechanical blocks. Install a new brake, if necessary.
Delayed brake engagement	• Air gap 's' too large	Check the air gap 's' (see Section 5.1). Install a new brake, if necessary (see Section 5.2).
	• Voltage applied to field coil (1.2) too high (residual voltage)	Check the supply voltage of the field coil (1.2) and correct faults, if found.
Brake release failure	• Voltage applied to field coil (1.2) too low or too high	Check the supply voltage of the field coil (1.2) and correct faults, if found.
	• Damaged friction surfaces of armature (4) and housing (2)	Install a new brake, if necessary (see Section 5.2).
	• Damaged field coil (1.2)	Check the resistance of the field coil (1.2). Install a new brake, if necessary (see Section 5.2).
	• Armature (4) blocked mechanically	Eliminate mechanical blocks. Install a new brake, if necessary (see Section 5.2).
Delayed brake release	• Voltage applied to field coil (1.2) too low	Check the supply voltage of the field coil (1.2) and correct faults, if found.
Brake torque too low	• Air gap 's' too large	Check the air gap 's' (see Section 5.1). Install a new brake, if necessary (see Section 5.2).
	• Brake operating temperature too high	Reduce the ambient temperature. Check the supply voltage of the field coil (1.2) and correct faults, if found. Reduce the switching work / switching power and cool the brake, if necessary.
	• Voltage (residual voltage) applied to field coil (1.2)	Check the supply voltage of the field coil (1.2) and correct faults, if found.
	• Oily, greasy or dirty friction surface(s)	Install a new brake (see Section 5.2).
	• Friction lining (if used) projects from the housing (2)	Install a new brake (see Section 5.2).

Table 42/1: Possible faults, causes and corrective actions (list not exhaustive)

9. Tools and measuring instruments for installation, maintenance and troubleshooting

Special tools and measuring instruments are required for installation (Section 4), maintenance and checks (Section 5.1) and troubleshooting (Section 8, non-exhaustive list of potential faults). The individual tools and instruments and their applications are described in Table 43/1.





Tools, measuring instruments	Description and application	Suitable for brake size	Design details
	Calibrated torque wrench for precise torque-controlled tightening and loosening of all screws to a defined M _A tightening torque	03, 04, 05, 06, 07, 08,	• 0 – 5 Nm
		09, 10, 11, 14, 16, 21	• 0 – 80 Nm
	Hex drive hexagon insert bit for use with calibrated torque wrench for tightening and loosening the mounting screws (10)	03, 04	AF 2.5 mm
		05, 06, 07, 08	AF 3.0 mm
		09, 16 ³⁾	AF 4.0 mm
		10, 11	AF 5.0 mm
		14, 16, 21	AF 6.0 mm
	Hex drive hexagon insert bit for use with calibrated torque wrench for tightening and loosening the set screws (8)	03, 04	AF 1.5 mm
		05, 06	AF 2.0 mm
		07, 08	AF 2.5 mm
		09, 10	AF 3.0 mm
		11, 14, 16, 21	AF 5.0 mm AF 6.0 mm
	Allen key for mounting screws (10) and set screws (8)	See information on hex drive hexagon insert bit	
	Feeler gauges for checking and measuring the air gap 's'	03, 04, 05, 06, 07, 08, 09, 10, 11, 14, 16, 21	Leaf thickness from 0.05 mm to 1.0 mm by 0.05 mm steps
	Multimeter (voltage, current, resistance) for measuring the supply voltage and ohmic resistance of the field coil (1.2)	03, 04, 05, 06, 07, 08, 09, 10, 11, 14, 16, 21	-

Table 43/1: Tools and measuring instruments for installation, maintenance and troubleshooting

IMPORTANT



Brake inspections and tests as well as service and maintenance operations must be carried out by the manufacturer of the machine (e.g. motor) and by qualified specialist or service personnel only. The specific maintenance instructions of the machine manufacturer (e.g. motor manufacturer) must take account of the requirements specified in Section 5.1 (Maintenance and checks) of these operating instructions.

³⁾ Brake mounting via M5 tapped holes (see Table 20/1, size 16).

10. Definitions

Based on: DIN VDE 0580:2011-11 (not exhaustive)

Switching torque M_1	torque acting on the shaft during brake or clutch slip
Rated torque M_2	switching torque specified by the manufacturer to identify the brake. The rated torque M_2 is the mean value of at least 3 measurements of the maximum switching torque M_1 after completion of the transient response.
Minimum transmissible torque M_4	highest torque that can be applied to the engaged brake or clutch without causing the brake/clutch to slip. Note: In the case of brakes and clutches exposed to purely static loads, the M_4 torque is commonly referred to as rated torque.
Residual torque M_5	torque transmitted by the released brake or clutch
Load torque M_6	torque acting on the drive of the engaged brake or clutch; determined by the power requirement of the driven machine at a given speed
Switching work W	heat generated by friction inside the brake or clutch as a result of the switching operation
Maximum switching work W_{max}	maximum switching work to which the brake or clutch may be exposed
Switching power P	switching work converted into heat per unit of time
Maximum switching power P_{max}	maximum permissible switching work converted into heat per unit of time
Coil ON time t_5	time between power on and power off
Coil OFF time t_6	time between power off and power on
Total cycle time t_7	coil ON time plus coil OFF time
Duty cycle	percentage relationship of coil ON time to total cycle time
Switching operation	one complete switching on and off operation
Switching frequency Z	number of regular switching operations per hour
Response delay during coupling t_{11}	time between power off (releasing systems) or power on (engaging systems) and beginning of torque increase
Rise time t_{12}	time it takes to reach 90% of the M_2 rated torque from the beginning of the torque increase
Coupling time t_1	response delay t_{11} plus rise time t_{12}
Response delay during disconnection t_{21}	time between power on (releasing systems) or power off (engaging systems) and beginning of torque decrease
Fall time t_{22}	time it takes for the torque from the beginning of the torque decrease to fall to 10% of the M_2 rated torque
Disconnection time t_2	response delay t_{21} plus fall time t_{22}
Slip time t_3	time from the beginning of the torque increase up to the end of the braking process (brakes) or until the synchronization torque M_3 has been reached (clutches)
Making time t_4	response delay t_{11} plus slip time t_3 (braking or acceleration time)
Operating condition at operating temperature	condition at which the steady-state temperature is reached. The operating temperature corresponds to the overtemperature according to DIN VDE 0580 plus the ambient temperature. Unless otherwise specified, the ambient temperature is 35°C.
Overtemperature $\Delta\theta_{31}$	difference between the temperature of the electromagnetic device or a part thereof and the ambient temperature
Limit temperatures of coil insulating materials	in accordance with DIN VDE 0580. The individual insulating materials are classified by insulation classes to DIN IEC 60085.
Rated voltage U_N	supply voltage specified by the manufacturer for voltage coils to identify the device or component

Rated current I_B	amperage determined by the manufacturer for the specified operating conditions. Unless otherwise specified, the rated current refers to the rated voltage, 20°C winding temperature and to the rated frequency for a given operating mode of field coils.
Rated power P_N	power value to identify the device or component
Rated power at 20°C winding temperature P_B	determined from the rated current of voltage-controlled devices and components and the R_{20} resistance at 20°C winding temperature

Other definitions (not included in DIN VDE 0580) applicable to High Torque brakes:

Air gap s	air gap of released High Torque brake
Rated air gap s_N	air gap of released High Torque brake when the brake is new
Max. operating air gap s_{Bmax}	maximum air gap of released High Torque brake at which the brake can be operated provided that the technical specifications are complied with
Closing time t_{c1}	time it takes for the High Torque brake to close mechanically after power has been turned off (beginning of power drop) (see chart in Fig. 45/1)
Activation time t_{c2}	time it takes for the transmissible torque M_4 (holding torque) to be reached almost completely after power has been turned off (beginning of power drop) (see chart in Fig. 45/1)
Opening time t_o	time it takes for the High Torque brake to open mechanically after power has been turned on (beginning of power rise) (see chart in Fig. 45/1)
Static test torque M_{4P}	highest torque that can be applied to the engaged brake at an ambient temperature of 20°C immediately after the break-in process of the new brake without causing any slip

The switching times (disconnection time t_2 and coupling time t_1) are defined in DIN VDE 0580. When using static systems (holding brakes), the switching times are also determined on the basis of the current profile (see Fig. 45/1, AC side power on and off) instead of using the DIN VDE 0580 definitions.

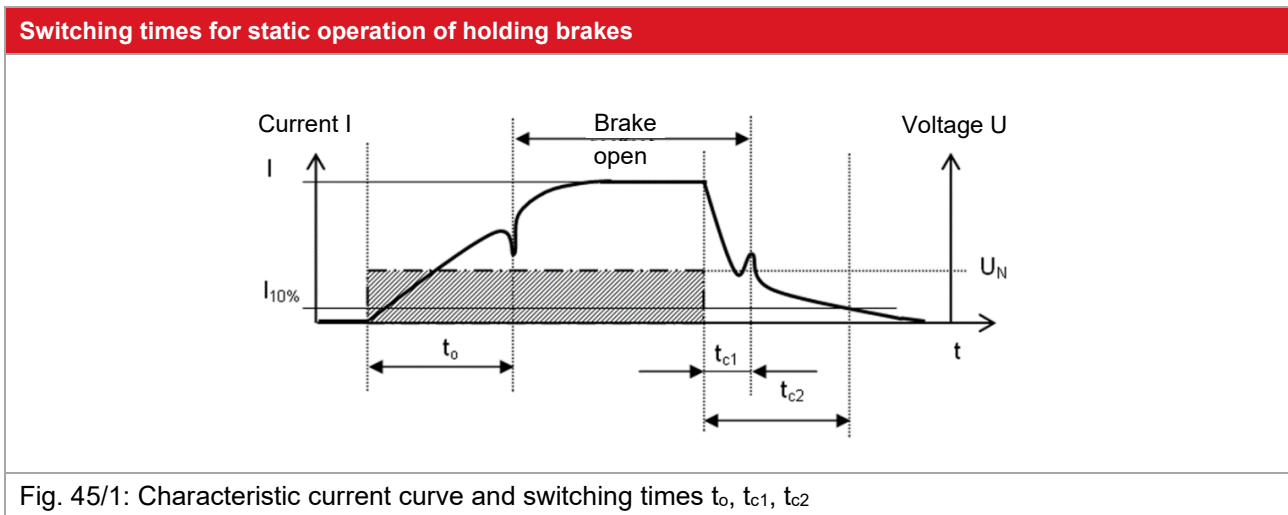

11. Technical specifications

Product built and tested to DIN VDE 0580

	Brake size											
	03	04	05	06	07	08	09	10	11	14	16	21
Min. transmissible torque M_4 [Nm]	0.4	2.5	5	9	12	15	22	32	60	80	140	280
Test torque M_{4P} [Nm] ⁴⁾	≥0.7	≥3.5	≥7	≥13	≥20	≥23	≥31	≥51	≥89	≥160	≥200	≥430
Max. speed n_{max} [rpm]	10000										6000	
Rated power P_N [W]	6	9	12	15	16.5	18	19	22.5	25	36.5	43	41.8
Closing time t_{c1} [ms]	13	20	25	25	25	29	40	60	50	65	60	300
Opening time t_o [ms]	24	35	50	60	90	130	100	200	220	280	450	350
Moment of inertia of armature system (AS) (armature type 800) J [kgcm ²]	0.019	0.09	0.39	0.55	0.83	1.35	2.73	4.1	14.7	27	51	200
Weight (types 86 611..P00) m [kg]	0.1	0.25	0.4	0.65	0.72	1.15	1.2	1.86	3.1	4.4	7.3	13.6
Rated air gap s_N [mm]	0.1 ^{+0.1}	0.15 ^{+0.1}	0.2 ^{+0.1}	0.2 ^{+0.1}	0.2 ^{+0.08}	0.3 ^{+0.1}	0.27 ^{+0.1}	0.3 ^{+0.1}	0.4 ^{+0.1}	0.3 ^{+0.1}	0.3 ^{+0.1}	0.4 ^{+0.1}
Operating air gap s_B [mm]	0.1 ^{+0.11}	0.15 ^{+0.12}	0.2 ^{+0.12}	0.2 ^{+0.14}	0.2 ^{+0.14}	0.3 ^{+0.2}	0.27 ^{+0.23}	0.3 ^{+0.16}	0.4 ^{+0.15}	0.3 ^{+0.3}	0.3 ^{+0.2}	0.4 ^{+0.22}
Max. operating air gap s_{Bmax} [mm]	0.21	0.27	0.32	0.34	0.34	0.5	0.5	0.46	0.55	0.6	0.50	0.62
Duty cycle [%]	max. 100											
Total cycle time t_T [s]	-											
Standard rated voltage U_N [VDC]	24											
Insulation class	F											
Pollution degree	2											
Protection rating	IP00											
Duty type / Brake type	S1, S2, S3											
	holding brake with emergency stops											

Table 46/1: Technical specifications

Rated operating conditions	
Tolerance of rated voltage U_N	±10%
Frequency range	±1% of rated frequency
Ambient temperature ϑ_{13} [°C]	-15 to +120
Relative humidity	30% to 80% within ambient temperature range
Other climatic conditions (Z)	3Z2 and 3Z14 to EN IEC 60721-3-3
Mechanical conditions (M)	3M12 to EN IEC 60721-3-3
Biological conditions (B)	3B1 to EN IEC 60721-3-3
Mechanically active substances (S)	3S6 to EN IEC 60721-3-3
Chemically active substances (C) or corrosivity category	C1 to EN ISO 9223
Installation height	up to 2000 m a.m.s.l.

Table 46/2: Rated operating conditions for High Torque brakes

⁴⁾ Determined at 20°C ambient temperature, immediately after the break-in process (see Table 47/1 or Table 47/2) of the new brake

	Brake size											
	03	04	05	06	07	08	09	10	11	14	16	21
Speed n [rpm]	200	200	200	120	120	100	100	100	100	80	80	80
Coil ON time t_5 [s]	0.15	0.15	0.15	0.15	0.15	0.15	0.15	0.15	0.15	0.15	0.15	0.15
Coil OFF time t_6 [s]	0.15	0.15	0.15	0.15	0.15	0.15	0.2	0.2	0.2	0.2	0.2	0.2
Break-in period t_{total} [s]	30	30	30	30	30	30	30	30	30	30	30	30

Table 47/1: Break-in process parameters for High Torque brakes after assembly and during the service life when equipped with an anti-parallel diode (free-wheeling diode) as protective circuit element

	Brake size											
	03	04	05	06	07	08	09	10	11	14	16	21
Speed n [rpm]	200	200	100	120	120	100	100	100	100	80	80	80
Coil ON time t_5 [s]	0.2	0.2	0.25	0.2	0.2	0.2	0.2	0.25	0.25	0.25	0.25	0.25
Coil OFF time t_6 [s]	0.1	0.1	0.1	0.1	0.1	0.1	0.1	0.1	0.1	0.1	0.1	0.1
Break-in period t_{total} [s]	30	30	30	30	30	30	30	30	30	30	30	30

Table 47/2: Break-in process parameters for High Torque brakes after assembly and during the service life when equipped with a varistor type S14K30 (for rated voltage $U_N = 24$ VDC) as protective circuit element (other varistor types for different rated voltages U_N may require different cycle times)

IMPORTANT

i Incorporation of the brake into the machine (e.g. motor) may have an impact on the friction pair and brake torque. Therefore, an additional break-in process is always required even for factory-burnished brakes to condition the friction surfaces and to stabilize the brake torque. After completion of the break-in process, check the (static) test torque M_{4P} . If the specified minimum value is not reached (see Table 46/1 or relevant offer drawing), repeat the break-in process using the parameters specified in Table 47/1 or Table 47/2. Then check the static test torque M_{4P} once again.

	Brake size											
	03	04	05	06	07	08	09	10	11	14	16	21
Total number of emergency stops Z_{total}	500	500	500	500	500	500	500	500	500	500	500	500
Switching operations (emergency stops) Z [h ⁻¹]	20											
Max. switching work W_{max} [J]	10	30	150	300	600	900	600	1200	1200	1400	1400	2000
Max. emergency stop speed n_{Nmax}	3000											

Table 47/1: Total number of emergency stops Z_{total} and maximum number of switching operations (emergency stops) per hour Z; maximum permissible switching work W_{max} and maximum permissible emergency stop speed n_{Nmax}

IMPORTANT

i In order to avoid overheating and potential damage to the brake and friction surfaces of the friction pair, ensure that the switching operations (emergency stops) per hour Z are evenly distributed.

Explanations on the technical specifications:

W_{\max} (maximum switching work) is the switching work that must not be exceeded during braking operations (emergency stops) at maximum speeds of 3000 rpm. Braking operations at speeds greater than 3000 rpm substantially reduce the maximum permissible switching work per switching operation. Such operation must be agreed with the manufacturer. The maximum number of switching operations (emergency stops) per hour Z and the resulting maximum permissible switching work W_{\max} are specified in Table 47/1 and/or in the offer drawing of the relevant component. The specified transmissible torques M_4 characterize the minimum transmissible torque of the brakes. Depending on the application, the switching torque M_1 and the effective transmissible torque M_4 may differ from the specified M_4 transmissible torque values. The switching torque M_1 depends on the speed (rpm). If the friction surfaces are contaminated with oil, grease or dirt, the transmissible torque M_4 and the switching torque M_1 may drop. The technical specifications apply after the break-in process has been completed with the specified break-in parameters (see Table 47/1 or Table 47/2).

Specific explanations of the opening and closing times:Opening time t_o :

The defined maximum opening time values t_o apply under the following conditions:

- Operation at rated voltage U_N within the permissible voltage range as specified in Table 46/2
- Temperature range of field coil (1.2) -15°C to 120°C
- Operation within the permissible operating air gap s_B according to Table 46/2

Closing time t_{c1} :

The defined maximum closing time t_{c1} values apply under the following conditions:

- Operation at rated voltage U_N within the permissible voltage range as specified in Table 46/2
- Temperature range of field coil (1.2) -15°C to 120°C
- DC side turn-off with varistor (e.g. type S10K30 for rated voltage $U_N = 24\text{ VDC}$) to limit the turn-off voltage
- Operation within the permissible operating air gap s_B according to Table 46/2

IMPORTANT

The closing time t_{c1} and the opening time t_o depend on the temperature of the field coil (1.2) and on the air gap 's' of the High Torque brake. As the air gap 's' of the High Torque brake increases, the opening times t_o are reduced and the closing times t_{c1} are extended.

The technical specifications in Table 46/1 and the rated operating conditions specified in Table 46/2 must be strictly observed during operation of the High Torque brakes.

The information in the High Torque Line brochure for brake types 86 611..K00 and 86 611..P00 and the instructions provided in the Technical Customer Information TKU 86 611..P01 must be followed.

Specifications subject to change without notice!

12. Product number / type number / version number

The product number to be quoted in purchase orders and required to identify the brake version consists of the type number followed by the 4-digit version number. Individual brake types may be available in different versions. So the version number identifies the relevant brake model.

Example:

Type number: 86 61116P00 Version number: 0001

Product number: 86 61107P00-0001

13. Specialist repair shops

Kendrion (Villingen) GmbH
Wilhelm-Binder-Str. 4-6
78048 Villingen-Schwenningen
Germany
Tel: +49 7721 877-1417

14. Revision history

Date of issue	Changes
15/11/2007	First issue.
18/02/2008	Text revisions.
15/05/2008	Text revisions.
30/12/2009	Text revisions.
23/06/2017	Updated reference to directives / standards (Low Voltage Directive, EMC Directive etc.). Added Sections 1.4 (EU Declaration of Conformity), 11 (Product number / type number / version number) and 13 (Revision history). Revised sections 2 (Product description), 3 (Installation), Explanations on the technical specifications, and 12 (Specialist repair shops). Changed layout (design) of operating instructions.
04/02/2019	Changed parameters for break-in process in Table 47/1. Added Table 47/2, Break-in process with varistor as protective circuit element. Added potential cause of faults in Section 8.
13/03/2020	Text revisions. Changed layout (design) of operating instructions.
02/03/2022	Complete revision of operating instructions. Revision of safety information. Deleted armature versions (armature types) 200, 400 and 500. Added armature version (armature type) 800 (replacement for armature types 400 and 500). Added High Torque brake types 86 61103K00, 86 61105K00/P00, 86 61107K00/P00, 86 61110K00/P00 86 61116P00/16K00 and 86 61121P00/21K00.

KENDRION

Kendrion (Villingen) GmbH

Wilhelm-Binder-Straße 4-6
78048 Villingen-Schwenningen
Germany

Tel: +49 7721 877-1417
Fax: +49 7721 877-1462

sales-ids@kendrion.com
www.kendrion.com

PRECISION. SAFETY. MOTION.

